

ÁÁÁÁ] æ^ ÁÚæc ÁŠã c

Sææ[ \* Á | @æã} ã&@ãð ÁÁ

GARUDAN®

GBH-3030



ANITA B, s.r.o.

Průmyslová 2453/7

680 01 Boskovice

Czech Republic

tel: +420 516 454 774

+420 516 453 496

fax: +420 516 452 751

e-mail: [info@anita.cz](mailto:info@anita.cz)

[www.garudan.cz](http://www.garudan.cz)

# CONTENTS

## 目录

1. RAME & MISCELLANEOUS COVER COMPONENTS I .....	01
机壳部件 I	
2. RAME & MISCELLANEOUS COVER COMPONENTS II .....	04
机壳部件 II	
3. MAIN SHAFT COMPONENTS.....	07
上轴关系	
4. HOOK DRIVING SHAFT COMPONENTS.....	10
下轴部件	
5. PRESSER& FEED COMPONENTS.....	12
送料、抬压脚部件	
6. NEEDLE BAR ROCKING COMPONENTS.....	15
摆针部件	
7. NEEDLE THREAD TRIMMER COMPONENTS.....	17
上切线部件	
8. BOBBIN THREAD TRIMMER COMPONENTS.....	20
下切线部件	
9. CLOTH CUTTING COMPONENTS.....	23
切布刀部件	
10. ACCESSORIE PART COMPONENTS.....	25
附件...	
11. THREAD STAND COMPONENTS.....	28
过线架部件	
12. CONTROL BOX COMPONENTS.....	29
电控部件	

# 1. FRAME & MISCELLANEOUS COVER COMPONENTS I

头部、外装关系I

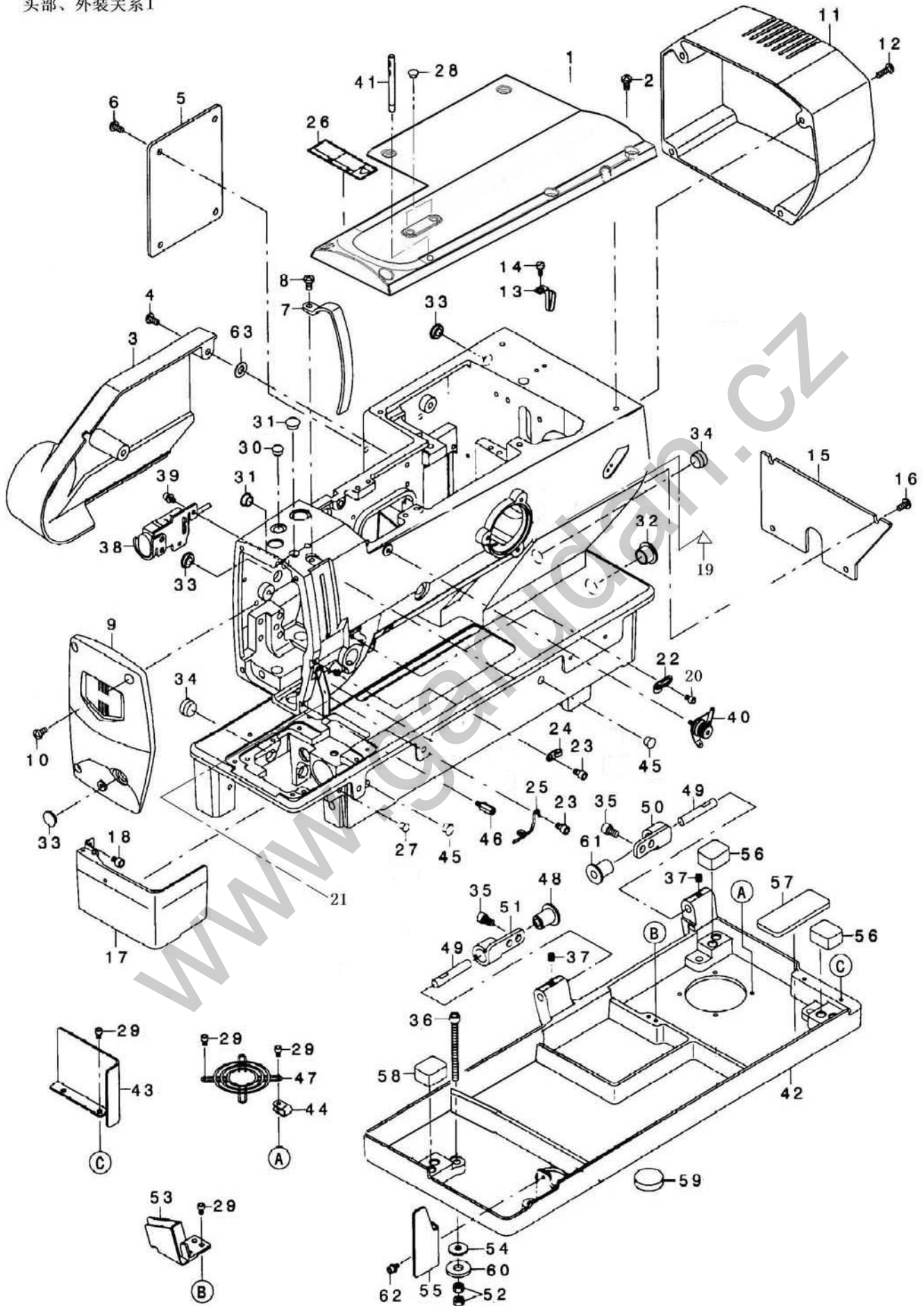

1. 头部、外装关系I				
FRAME&MISCELLANEOUS COVER COMPONENTS I				
序号 NO.	件号 Part No.	描述	Description	数量
1	20003569	上盖	UPPER COVER	1
2	10003883	上盖螺钉	SCREW	6
3	20003592	左盖	LEFT COVER	1
4	10003883	左盖螺钉	SCREW	2
5	20003383	左盖板	LEFT COVER B	1
6	10003883	左盖板螺钉	SCREW	4
7	20003373	挑线杆防护罩	THREAD TAKE UP LEVER COVER	1
8	10003883	挑线杆防护螺钉	SCREW	1
9	20003379	面板	FRONT COVER	1
10	10003883	面板螺钉	SCREW	3
11	20003595	后罩	MOTER COVER	1
12	10003827	后罩螺钉	SCREW M5 L=16	4
13	10003446	总线夹	OIL TUBE HOLDER	1
14	10003399	电线夹螺钉	SCREW M4 L=10	1
15	20003380	后盖	REAR COVER	1
16	10003883	后盖螺钉	SCREW	4
17	20000226	底板前盖板组件	HOOK OIL SHIELD COVER COMPL.	1
18	10003881	底板前盖板螺钉	HEXAGON SOCKET HEAD SCREW M5*6	2
19	10005987	接地标志	GROUNDING SYMBOL	1
20	10003399	右线钩螺钉	SCREW M4 L=6	1
21	10003359	过线槽	THREAD GUIDE TROUGH	1
22	10003419	右线钩	TAKE-UP THREAD GUIDE A	1
23	10003396	螺钉	SCREW M5 L=8	2
24	10003423	左线钩	TAKE-UP THREAD GUIDE B	1
25	10003873	下过线钩	NEEDLE BAR THREAD GUIDE	1
26	10008936	安全指示牌	SAFETY LABEL 12	1
27	10003426	底板前盖板垫	RUBBER PLUG	1
28	10000091	上盖前油塞	PLUG D=7.5 L=3.5	2
29	10003399	螺钉	SCREW M4 L=6	6
30	10011136	背部前端油塞	RUBBER PLUG	1
31	10011099	油塞	RUBBER PLUG	2
32	10003880	底板后端油塞	RUBBER PLUG	1
33	10011099	油塞	RUBBER PLUG D=12.5 L=4	3
34	10003871	油塞	PLUG	2
35	10003402	机头铰链螺钉	SCREW M6 L=10	4
36	10003832	底座锁紧螺钉	HEXAGON BOLT	4
37	10011232	连接销紧定螺钉	SCREW M6 L=6	2
38	10003870	点动开关组件	SWITCH ASM.	1
39	10003875	点动开关组件螺钉	SCREW	2
40	10000131	上夹线器组件	PRE TENSION CONTROLLER ASM.	1
41	10000167	两眼过线柱	THREAD GUIDE BAR	1
42	10003878	底座	BED BASE	1
43	20003381	底座后盖板	BED REAR COVER	1
44	10003358	电线夹	CABLE CLAMP	1
45	10000405	油塞	RUBBER PLUG	2
46	10003413	眼睛防护罩安装柱	VCS STUD A	1

# 1. FRAME & MISCELLANEOUS COVER COMPONENTS I

头部、外装关系I

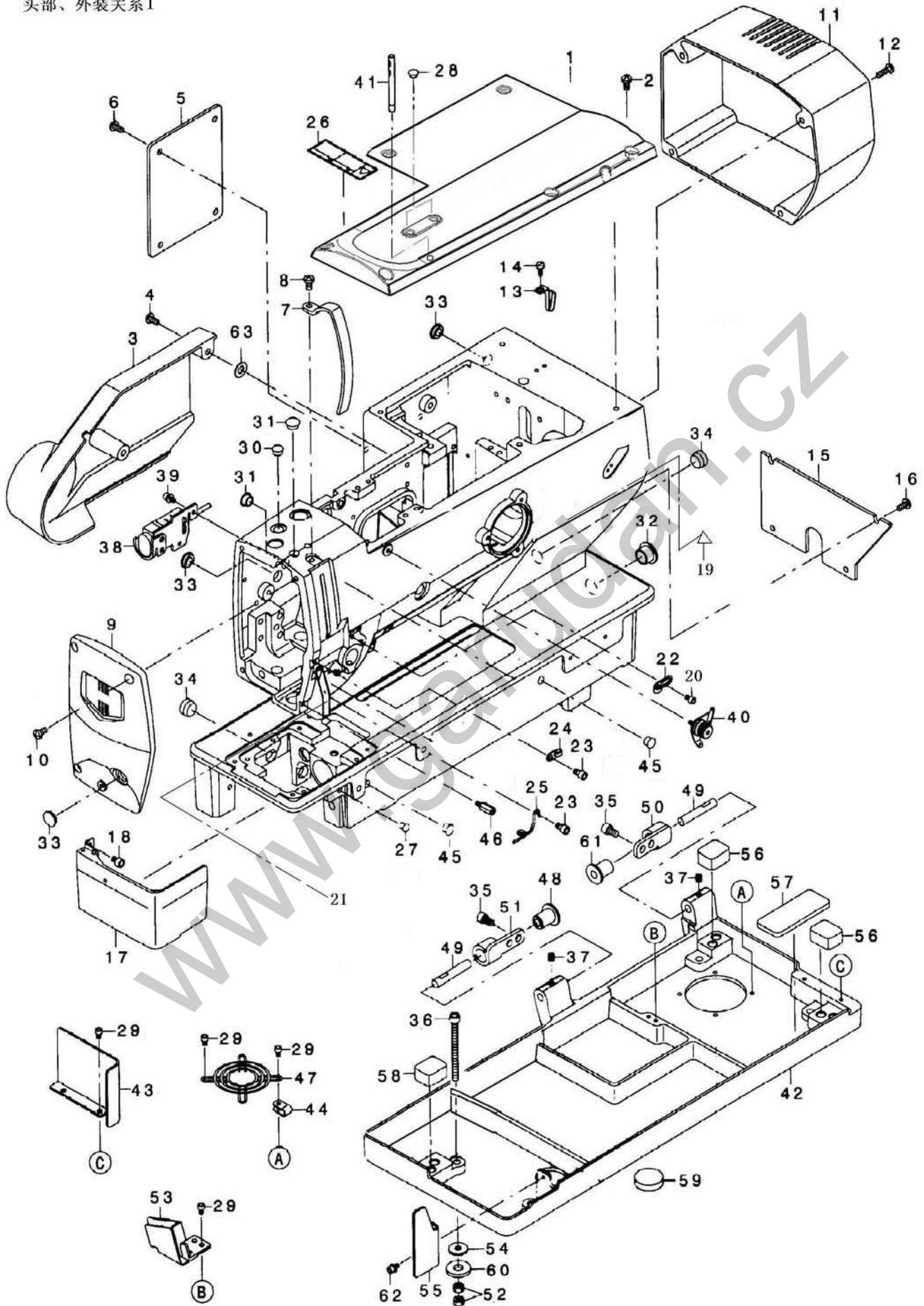

47	10003397	风扇安装架组件	FINGER GUARD	1
48	10003347	机头铰链套	HINGE BUSH	1
49	10003884	连接销	HINGE PIN	2
50	10003443	机头后铰链	HINGE PLATE A	1
51	10003831	机头前铰链	HINGE PLATE B	1
52	10005504	调节螺母	NUT M6	8
53	10003888	安全开关组件	SAFETY SWITCH COVER	1
54	10003395	底座锁紧螺钉垫片	WASHER 6.1X18.5X2	4
55	10003453	挡油板	OIL SHIELD	1
56	10003415	底座垫II	RUBBER A	2
57	10003829	底座长垫	CUSHION	1
58	10003415	底座垫I	RUBBER	1
59	10003451	底座圆垫	Z STOPPER RUBBER	1
60	10003357	底座橡胶垫片	RUBBER CUSHION(B)	4
61	10003350	机头铰链橡胶套	RUBBER HINGE	1
62	10003875	挡油板螺钉	SCREW	1
63	10003353	左盖垫	CLOTH PLATE WASHER	1

www.garudan.cz

## 2. FRAME & MISCELLANEOUS COVER COMPONENTS II

机壳部件II

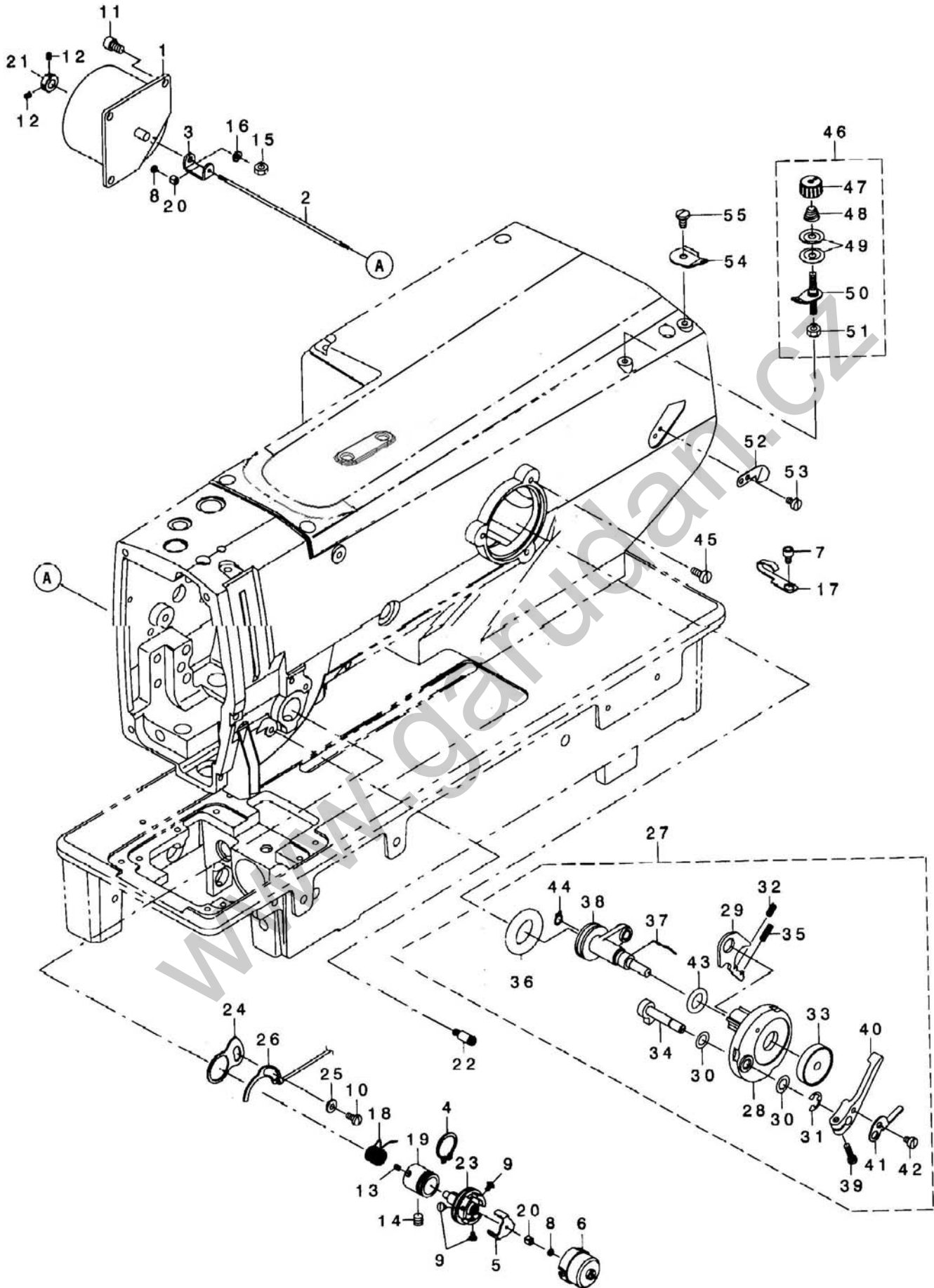



2. 机壳部件 II				
FRAME&MISCELLANEOUS COVER COMPONENTS II				
序号 NO.	图号 Part No.	描述	Description	数量
1	10000650	夹线电磁铁	ASSY_AT_SOLENOID	1
2	10000742	连接杆	AT_SHAFT	1
3	10000651	夹线电磁铁连接架	AT_SHAFT HOLDER	1
4	10000652	夹线器座挡圈	RETAINING RING	1
5	10000755	夹线三分盘	DISK_STOPPER	1
6	10000756	夹线器外盖	DISK_STOPPER HOLDER_CAP	1
7	10003399	电线夹螺钉	SCREW M4 L=6	4
8	10000754	连接杆螺母锁紧螺母	NUT	2
9	10000743	外盖螺钉	SCREW	3
10	10000731	绝缘片螺钉	SCREW M4 L=8	1
11	10005139	夹线电磁铁螺钉	SCREW M L=8	3
12	10013019	挡圈螺钉	SCREW	2
13	10000746	夹线器座螺钉	SCREW M3 L=4	1
14	10011232	夹线器紧固螺钉	SCREW M6 L=6	1
15	10009471	连接铁芯螺母	NUT	1
16	10005415	连接铁芯螺钉垫圈	SPRING WASHER	1
17	10001122	油管夹	LUBRICATING OIL WICK STOPPER	4
18	10000069	挑线簧	TAKE-UP SPRING	1
19	10000749	夹线器座	THREAD TENSION POST BASE	1
20	10000753	连接杆螺母	THREAD TENSION SHAFT COLLAR	2
21	10000732	夹线电磁铁挡圈	THRUST COLLAR	1
22	10007123	缓冲垫架螺钉	UTT_SUSPENSION SCREW_9	1
23	10000766	三分盘组件	ASSY_THREAD TENSION_POST	1
24	10000741	传感片内绝缘片	GUIDE PLATE	1
25	10000752	传感片外绝缘片	BUSHING	1
26	20000299	断线检测传感片组件	THREAD BREAK DETECTOR A	1
27	10000744	绕线器组件	ASSY_BOBBIN_THREAD WINDER	1
28	10011096	梭芯卷线体组件	BOBBIN FITTING BASIS COMPL.	1
29	10004497	控制板	ADJUSTING PLATE	1
30	10004486	薄垫片	VERTICAL ROLLER WASHER	2
31	10013038	绕线器凸轴挡圈	E-RING	1
32	10004494	弹簧	PRESSER FOOT SPRING	1
33	10000822	卷线轴垫	BOBBIN CUSHION	1
34	10006151	定位块	BOBBIN CAM SHAFT COMPLE.	1
35	10004501	弹簧	SPRING	1
36	10000757	橡胶轮	BTW RUBBER_RING	1
37	10009937	锁心弹簧	LATCH SPRING	1
38	10000823	摆动板组件	ASSY_BTW_SHAFT	1
39	10000735	卷线手柄螺钉	SCREW 9/64 -40 L=13.5	1
40	10000736	卷线手柄	BOBBIN LEVER	1
41	10000737	绕线调节板	BOBBIN ADJUSTING PLATE	1
42	10000759	线量调节板螺钉	SCREW 9/64 -40 L=5.0	1
43	10004485	绕线轴O型圈	RUBBER_RING	1
44	10006142	绕线器摆动板轴挡圈	RETAINING RING	1
45	10011101	绕线器螺钉	SCREW 11/64X40 L=11	3
46	10003088	绕线夹线器组件	BOBBIN_THREAD TENSION ASM.	1

## 2. FRAME & MISCELLANEOUS COVER COMPONENTS II

机壳部件II

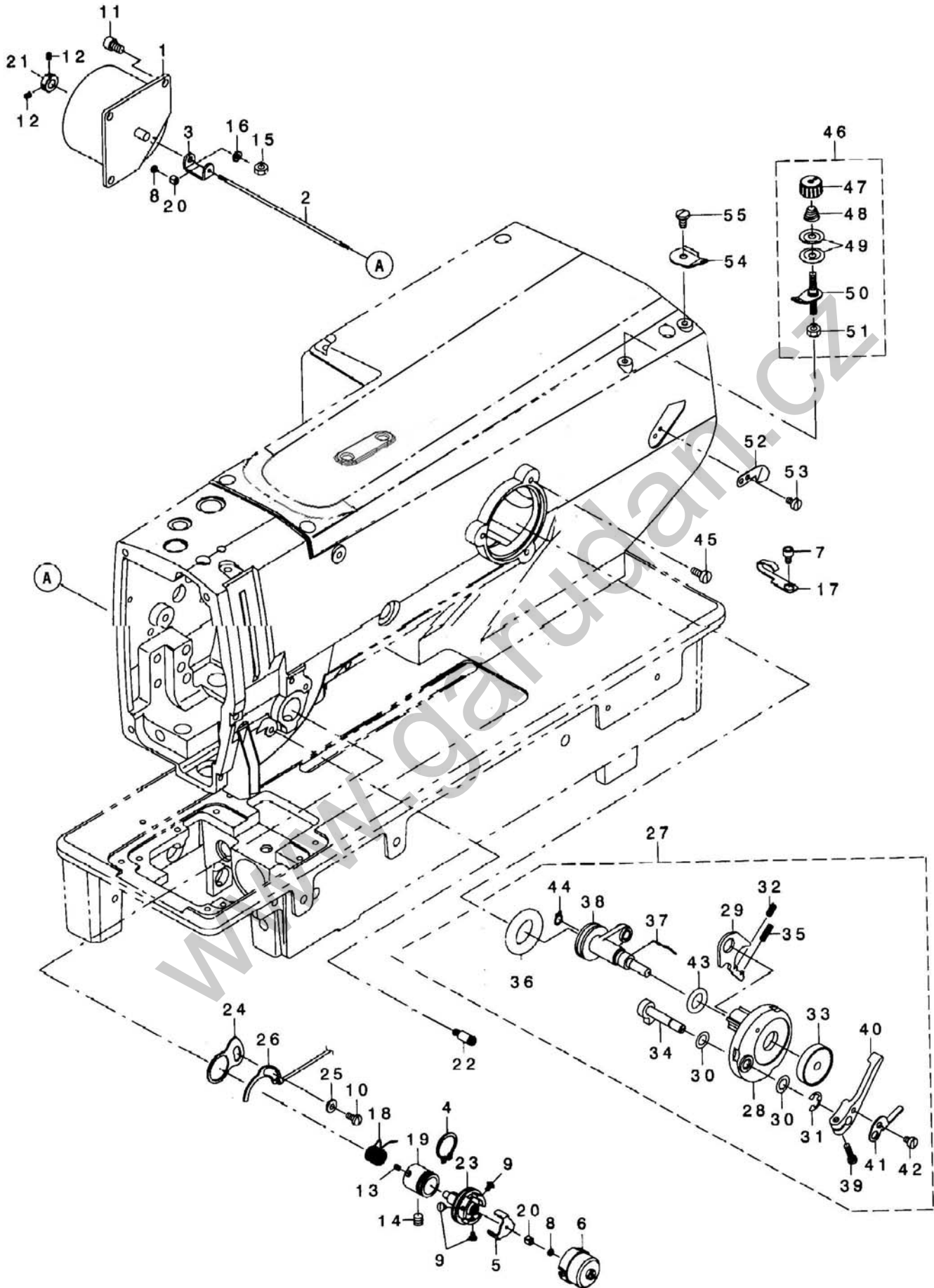

47	10004503	塑料夹线螺母	THREAD TENSION NUT	1
48	10004391	夹线簧	THREAD TENSION SPRING	1
49	10004393	夹线板	BOBBIN WINDER TENSION DISC	2
50	10003089	中过线板	BOBBIN THREAD TENSION ROD ASM.	1
51	10004507	夹线器螺母	NUT 11/64-40	1
52	10011149	绕线切刀	THREAD CUTTER	1
53	10000164	绕线切刀螺钉	SCREW 1/8-44 L=2.9	2
54	10000733	绕线过线板	THREAD GUIDE	1
55	10010668	绕线过线板螺钉	SCREW 11/64-40 L=7.8	1

www.garudan.cz

### 3. MAIN SHAFT COMPONENTS

上轴关系

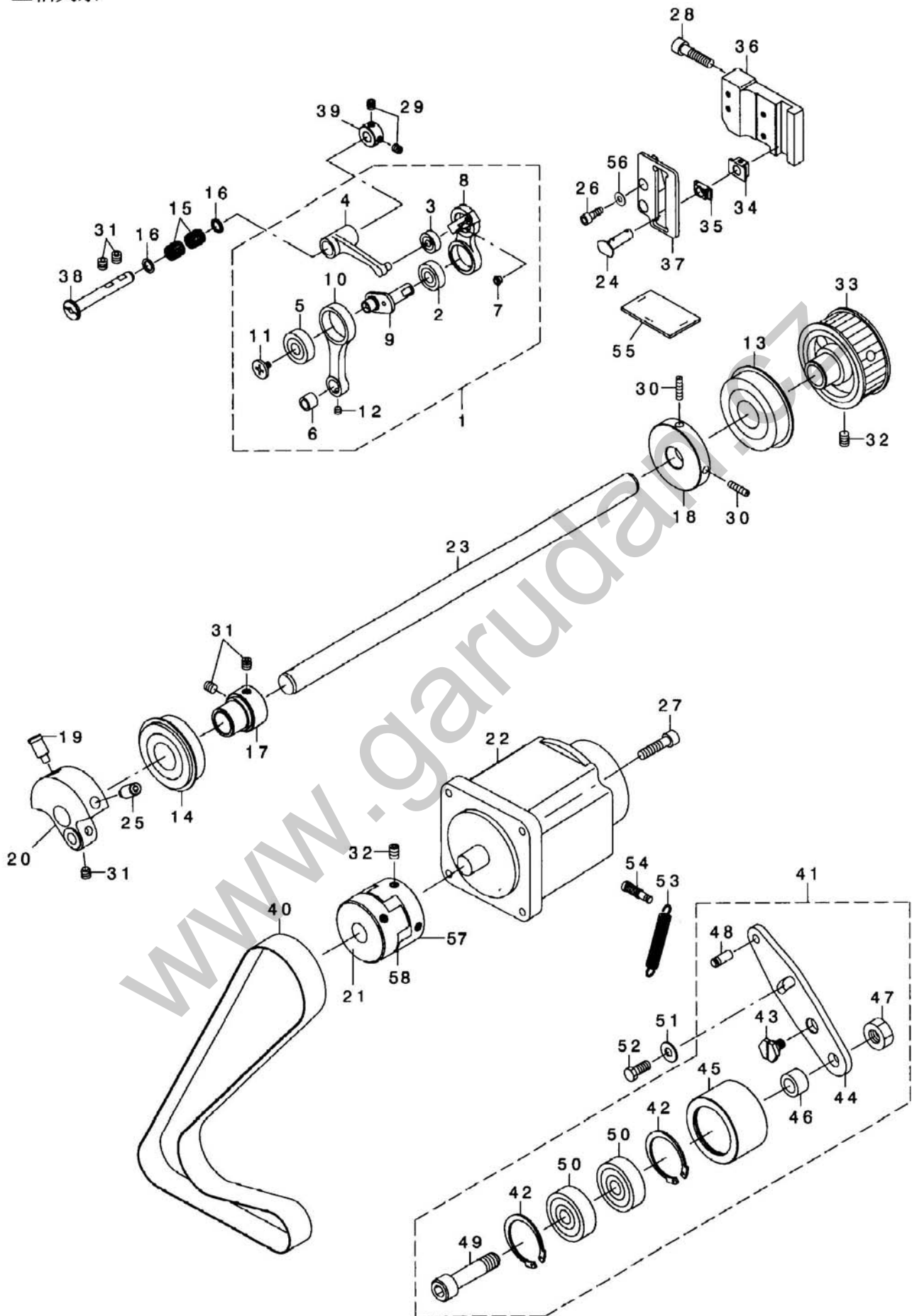

3. 上轴关系				
MAIN SHAFT&THREAD COMPONENTS				
序号 NO.	图号 Part No.	描述	Description	数量
1	10003204	挑线杆组件	THREAD TAKE UP ASM.	1
2	10009777	挑线杆大轴承	BEARING	1
3	10003552	挑线杆小轴承	BEARING	1
4	10000844	挑线连杆	THREAD TAKE UP CRANK	1
5	10014511	挑线连杆轴承	BUSHING	1
6	10000847	针杆连杆套	BUSH	1
7	10004161	挑线杆过线套	THREAD PASS BUSH	1
8	10000856	挑线杆	LINK TAKE UP	1
9	10000846	挑线曲柄	NEEDLE BAR CRANK	1
10	10000857	针杆连杆	NEEDLE BAR CRANK ROD	1
11	10010537	挑线曲柄左旋螺钉	LEFT SCREW	1
12	10009074	挑线连杆铰链轴螺钉	SET SCREW M4 L=4	1
13	10025862	上轴后轴承	BEARING	1
14	10025881	上轴前轴承	BEARING	1
15	10005747	挑线杆铰链轴滚针轴承	BEARING	2
16	10005786	挑线杆铰链轴滚针轴承挡圈	BEARING SUPPORT	2
17	10000839	上轴前轴套	BEARING HOLDER	1
18	10000867	绕线主动轮	BOBBIN WINDER DRIVING WHEEL	1
19	10000862	针杆曲柄定位螺钉	COUNTER WEIGHT SCREW	1
20	10000861	针杆曲柄	COUNTER WEIGHT	1
21	10000868	连接前块	COUPLING	1
22	10025119	上轴伺服电机	AC SERVO MOTOR	1
23	10000841	上轴	MAIN SHAFT	1
24	10003177	挑线连杆铰链轴	NEEDLE CRANK SHAFT	1
25	10000831	针杆曲柄紧定螺钉	SCREW M8 L=16	1
26	10000863	前导轨螺钉	SCREW M4 L=12	2
27	10000860	上轴伺服电机螺钉	SCREW M5 L=20	4
28	10009171	滑块槽螺钉	SCREW M6 L=25	3
29	10012162	挑线曲柄轴挡圈螺钉	SCREW M5 L=5	2
30	10011062	主动轮螺钉	SCREW 11/64-40 L=15.5	2
31	10011232	螺钉	SCREW M6 L=6	6
32	10000314	上轴带轮螺钉	SCREW M6 L=8	6
33	10000779	上轴带轮组件	SPROCKET A	1
34	10000824	针杆滑块	SQUARE_BLOCK	1
35	10003176	针杆前滑块	SQUARE_BLOCK B	1
36	10000833	针杆滑块槽	SQUARE_BLOCK_GUIDE	1
37	10000832	针杆滑块前导轨	SQUARE_BLOCK_GUIDE B	1
38	10000855	挑线曲柄销	THREAD TAKE UP CRANK SHAFT	1
39	10000845	挑线曲柄销挡圈	THRUST COLLAR D=7 W=8	1
40	10000842	同步齿形带	TIMING BELT	1
41	20000359	惰轮组件	IDLER ASM.	1
42	10003239	惰轮挡圈	RETAINING RING	2
43	10000835	惰轮组件固定螺钉	HINGE SCREW	1
44	10000877	惰轮调节板	IDLER_FIXED_PLATE	1
45	10000875	惰轮	IDLER PULLEY	1
46	10000899	挡圈	INTERMEDIATE SPROCKET WASHER	1

### 3. MAIN SHAFT COMPONENTS

上轴关系

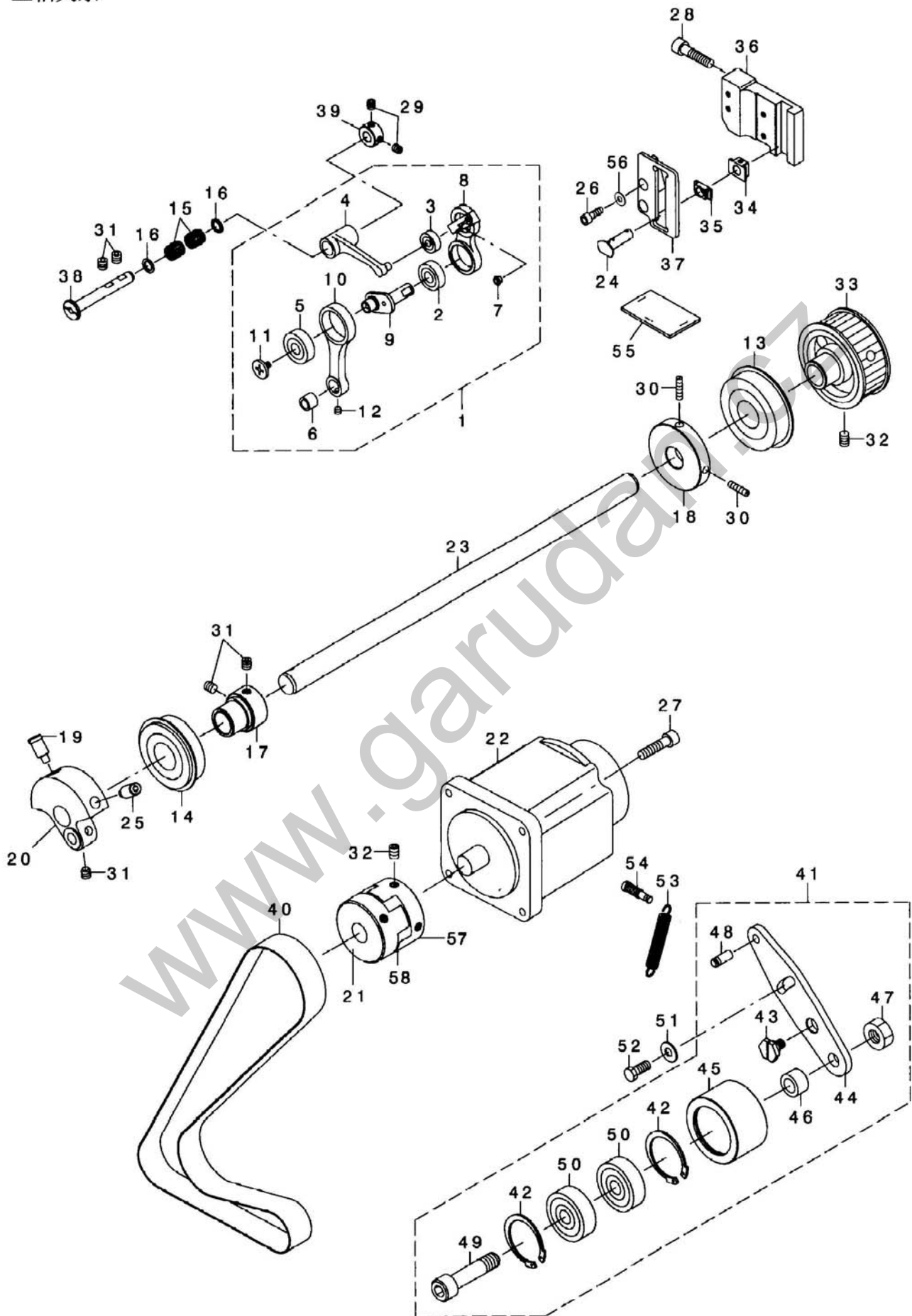

47	10000876	惰轮螺母	NUT M10	1
48	10000879	惰轮弹性挂销	FEED LEVER SPRING HOOK	1
49	10000874	惰轮螺栓	SCREW M10 L=42.5	1
50	10003594	惰轮轴承	BALL BEARING	2
51	10000836	惰轮组件调节螺钉垫圈	WASHER	1
52	10000865	惰轮组件调节螺钉	SCREW M6 L=14	1
53	10000866	复位弹簧	ADJUSTING_SPRING	1
54	10000837	复位弹簧挂销	SUSPENSION_SCREW	1
55	10000834	挡油毡	NEEDLE ROD CRANK LUBRICATING	1
56	10000864	滑块槽前导轨螺钉垫片	WASHER	2
57	10000838	连接后块	COUPLING	1
58	10011227	橡胶连接块	RUBBER COUPLING	1

www.garudan.cz

#### 4. HOOK DRIVING SHAFT COMPONENTS

下轴部件

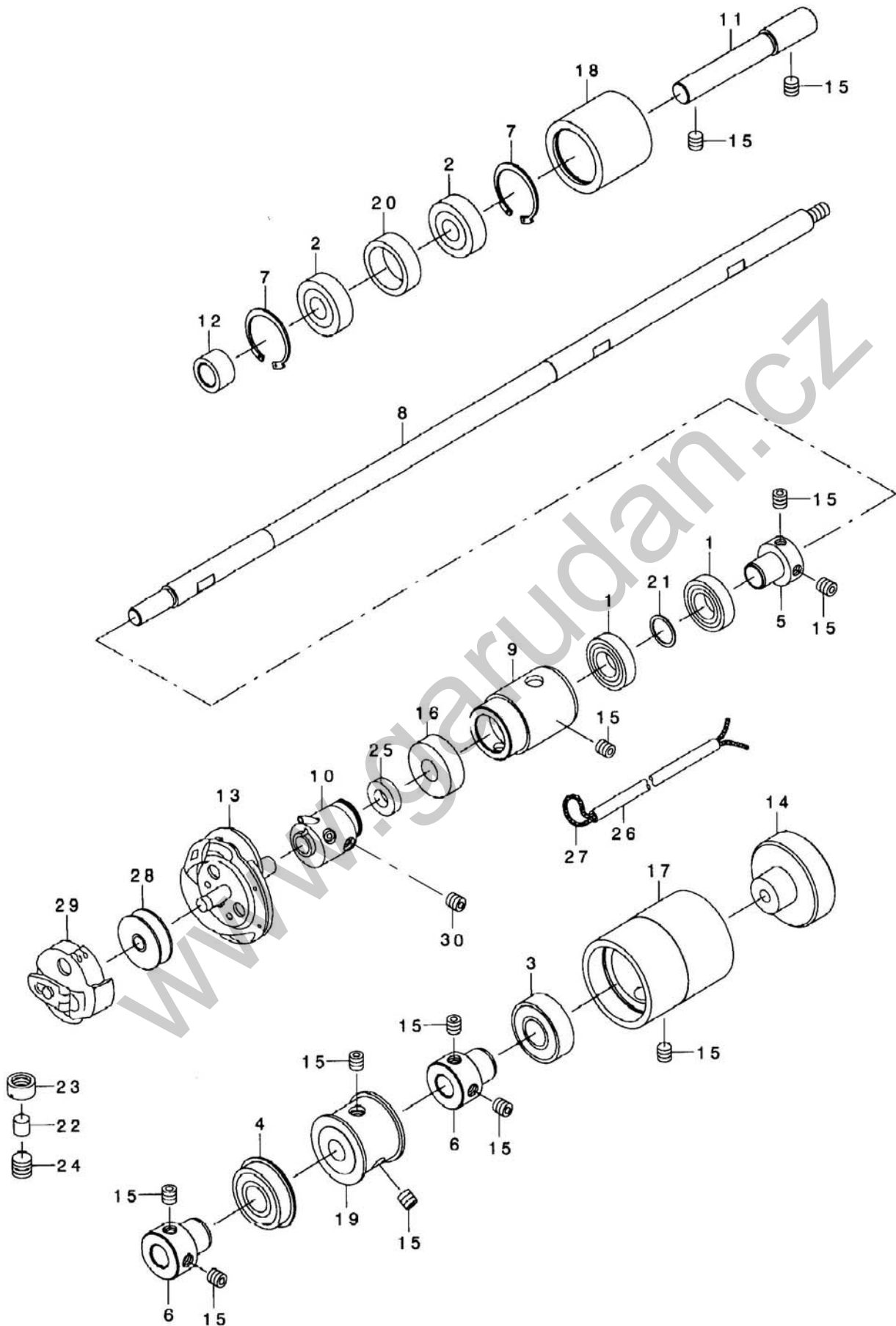



4. 下轴部件				
HOOK DRIVING SHAFT COMPONENTS				
序号 NO.	图号 Part No.	描述	Description	数量
1	10007410	下轴前轴套轴承	BEARING	2
2	10003544	辅助带轮轴承	BALL BEARING	2
3	10003581	下轴后轴套轴承	BEARING	1
4	10003600	下轴中轴套轴承	BEARING	1
5	10000897	下轴前轴套	BEARING_SUPPORT	1
6	10000891	下轴中轴套	BUSH	2
7	10000929	轴承挡圈	RETAINING RING	2
8	10000892	下轴	HOOK_DRIVING_SHAFT	1
9	10000895	下轴前套	HOOK_DRIVING_SHAFT_METAL	1
10	10000902	旋梭供油套组件	HOOK SLEEVE ASM.	1
11	10000898	辅助带轮轴	INTERMEDIATE SPROCKET SHAFT	1
12	10000899	辅助带轮轴挡圈	INTERMEDIATE SPROCKET WASHER	1
13	10003803	旋梭	HOOK COMPL.	1
14	10000775	下轴手轮	CROWN KNOB	1
15	10011232	螺钉	SCREW M6 L=6	12
16	10000883	供油套大毛毡	FELT	1
17	10000893	下轴后轴套大套	BEARING_SUPPORT	1
18	10000900	辅助带轮	SPROCKET_B	1
19	10000774	下轴带轮	SPROCKET_C	1
20	10000901	轴承隔圈	INTERMEDIATE SPROCKET RING	1
21	10000896	下轴前轴套波形垫圈	WASHER	1
22	10000887	油量调节柱	ADJUSTING SHAFT	1
23	10000885	油量调节螺母	ADJUSTING_NUT	1
24	10000884	油量调节螺钉	SCREW M8X8	1
25	10000882	供油套小毛毡	FELT	1
26	10007800	供油套软管	TUBE	1
27	10008101	供油管油线	OIL WICK	1
28	10000880	梭芯	BOBBIN	1
29	10003801	梭壳	BOBBIN CASE ASM.	1
30	10000881	旋梭供油套螺钉	SCREW	4

# 5. PRESSER & FEED COMPONENTS

压脚、送料部件

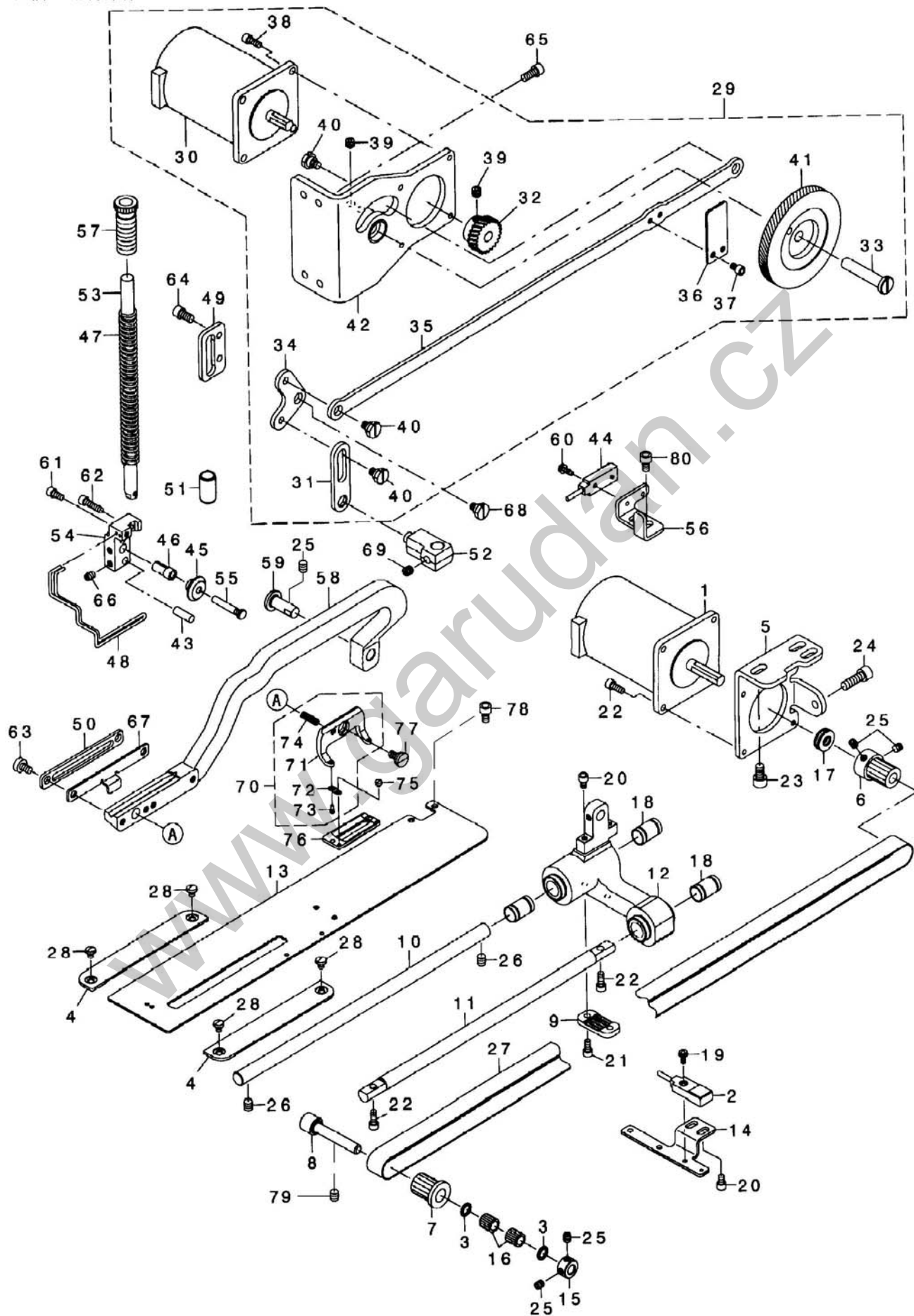

5. 压脚、送料部件				
PRESSER & FEED COMPONENTS				
序号 NO.	图号 Part No.	描述	Description	数量
1	10000796	送料电机	FEED MOTOR ASS'Y	1
2	10001007	下切线感应器	FEED SENSOR ASS'Y	1
3	10000004	送料带轮轴承挡片	BEARING SUPPORT	2
4	10000005	左右盖板	THROAT PLATE BASE COVER	2
5	10000955	送料电机固定板	MOTOR BRACKET	1
6	10000970	送布驱动轮组件	PULLEY_B	1
7	10000056	送料带轮组件	PULLEY_C	1
8	10000003	带轮轴	SUPPORT_SHAFT	1
9	10000067	同步带固定块	TIMING BELT HOLDER	1
10	10000000	送料轴	FEED_SHAFT	1
11	10000066	送料导向轴	FEED GUIDE SHAFT	1
12	10000945	送料架	FEED_BASE	1
13	10000931	送料板	WORK_CLAMP_CARRIER	1
14	10000957	送料传感器固定板	SENSOR_PLATE	1
15	10000002	送料带轮挡圈	THRUST COLLAR D=7 W=8	1
16	10005747	送料带轮轴承	BEARING	2
17	10000007	单向推力球轴承	BEARING	1
18	10003681	轴承	BEARING	3
19	10000984	送料传感器固定螺钉	SCREW M3X10	1
20	10003399	螺钉	SCREW M4 L=6	4
21	10003399	同步带固定块固定螺钉	SCREW M4 L=8	2
22	10000342	螺钉	SCREW M4 L=10	6
23	10003402	送料电机固定板短螺钉	SCREW M6 L=10	3
24	10010735	送料电机固定板长螺钉	SCREW M6 L=18	1
25	10012162	螺钉	SCREW M5 L=5	5
26	10011232	螺钉	SCREW M6 L=6	2
27	10000001	送料同步带	TIMING BELT	1
28	10000019	左右盖板螺钉	SCREW M4 L=5	4
29	20007581	拾压脚电机组件	ASSY_PBL_GEAR_MODULE	1
30	10000018	拾压脚电机	CLAMP MOTOR ASS'Y	1
31	10000795	拾压脚前曲柄	PBL_FRONT_LINK	1
32	10000794	拾压脚驱动齿轮	PBL_GEAR'S	1
33	10000946	拾压脚齿轮轴	PBL_GEAR_SHAFT	1
34	10000793	拾压脚曲柄	PBL_L_LINK	1
35	10000064	拾压脚长连杆	PBL_LONG_ROD	1
36	10000947	传感器挡片	PBL_SENSOR_PLATE	1
37	10003399	传感器挡片固定螺钉	SCREW M4 L=6	2
38	10000863	拾压脚电机固定螺钉	SCREW M4 L=10	4
39	10000933	拾压脚齿轮轴紧定螺钉	SCREW M6 L=5	5
40	10000261	螺钉	SHOULDER SCREW D8 H3.2	4
41	10000965	拾压脚齿轮	ASSY_PBL_GEAR_L	1
42	10000967	拾压脚电机固定板组件	ASSY_PBL_MOTOR_BASE	1
43	10000939	压杆纵向导销	PIN, SHORT	1
44	10001007	下切线感应器	CLAMP SENSOR ASS'Y	1
45	10000937	滑动滚子	SLIDE ROLLER	1
46	10000936	滑动滚子导套	COLLAR	1

# 5. PRESSER & FEED COMPONENTS

压脚、送料部件

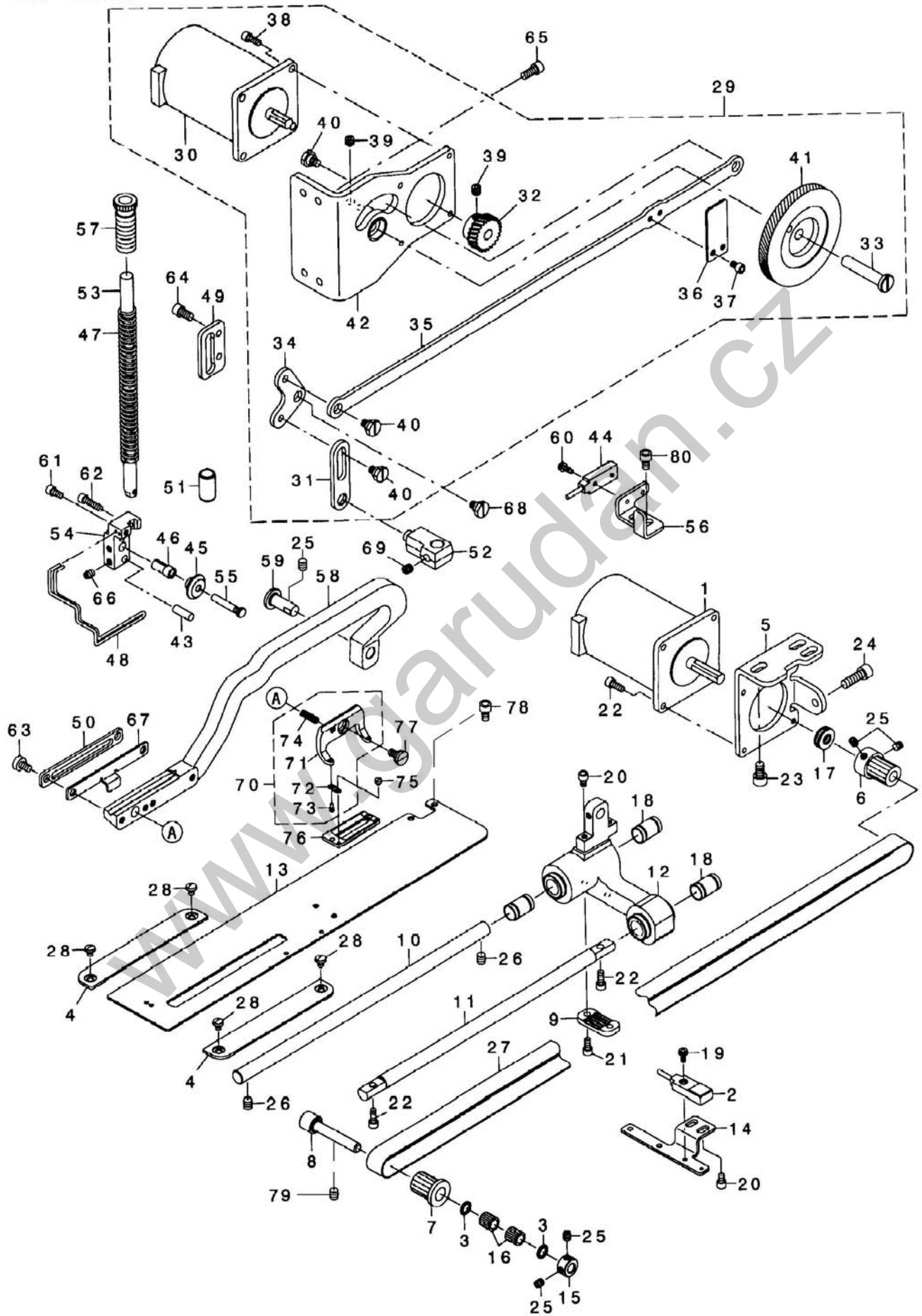

47	10000949	压杆簧	PBL_COLL_SPRING	1
48	10000950	护指架	PBL_FINGER_GUARD	1
49	10000948	拾压脚导板	PLB_GUIDE	1
50	10000942	压脚纵向导板	PBL_LIFTING_PLATE	1
51	10000934	压杆导套	PBL_METAL	1
52	10000932	拾压脚导块	PBL_POSITION_BRACKET	1
53	10000931	压杆	PBL_PRESSER_BAR	1
54	10000935	压杆连接块	PBL_ROLLER_BASE	1
55	10000938	滑动滚子连接销	PBL_ROLLER_SHAFT	1
56	10000958	拾压脚传感器固定板	PBL_SENSOR_BASE	1
57	10000930	调压螺钉	PBL_SPRING_REGULATOR	1
58	10000944	拾压脚导架	PBL_WORK_CLAMP_ARM	1
59	10000065	拾压脚导架销	PBL_WORK_CLAMP_ARM_SHAFT	1
60	10000984	拾压脚传感器固定螺钉	SCREW M3X10	1
61	10012553	护指架螺钉	SCREW M4 L=8	1
62	10009103	压杆连接块固定螺钉	SCREW M4 L=16	1
63	10000943	压脚纵向导板螺钉	SCREW M5 L=8	2
64	10005490	拾压脚导板固定螺钉	SCREW M5 L=10	4
65	10005139	拾压脚电机固定板螺钉	SCREW M5 L=12	4
66	10012162	滑动滚子导套紧定螺钉	SCREW M5 L=6	2
67	10000941	上切刀复位板	UTT_CLOSE_CAM	1
68	10000261	拾压脚前曲柄轴位螺钉	SHOULDER SCREW D8 H3.2	1
69	10000933	拾压脚导块固定螺钉	SCREW M6 L=5	1
70	10000960	拾压脚柄组件	WORK_CLAMP_CHECK HOLDER	1
71	10000008	压脚柄	WORK_CLAMP_CHECK HOLDER	1
72	10000961	拾压脚弹簧片	WORK_CLAMP_CHECK SPRING	2
73	10000068	压脚连接销	WORK_CLAMP_CHECK SPRING SET PI	2
74	10000009	拾压脚弹簧	WORK_CLAMP_CHECK SPRING SPRING	1
75	10000951	压脚连接螺钉	SCREW 3/32-56 L=1.9	2
76	10000962	拾压脚底板组件	PRESSER	1
77	10000940	拾压脚轴位螺钉	HINGE SCREW D=7.94 H=2	1
78	10003399	送料板固定螺钉	SCREW	2
79	10009074	带轮轴定位螺钉	SCREW	1
80	10010685	拾压脚传感器固定板螺钉	SCREW	2

# 6. NEEDLE BAR ROCKING COMPONENTS

摆针部件

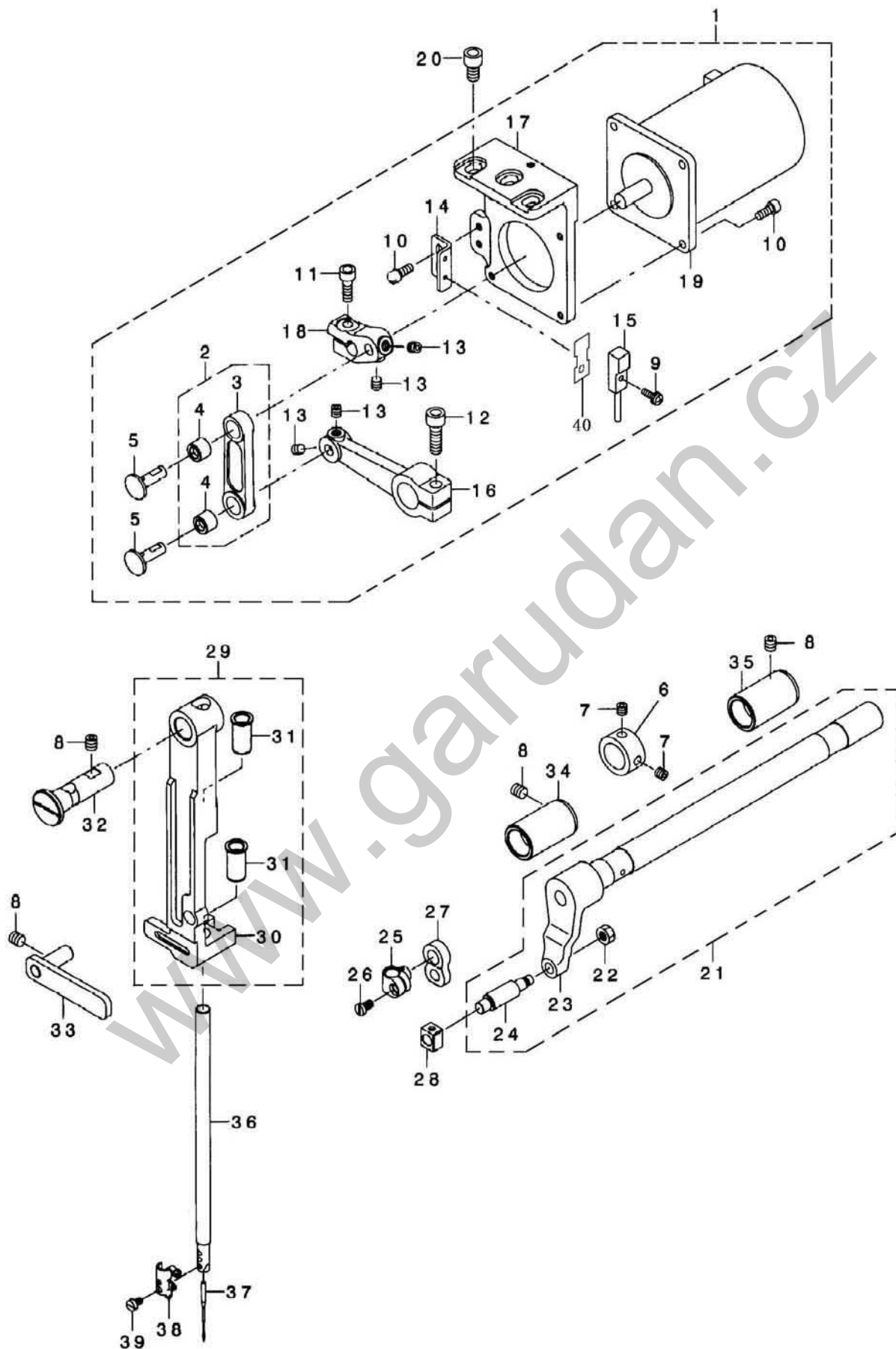

6. 摆针部件				
NEEDLE BAR ROCKING COMPONENTS				
序号 NO.	图号 Part No.	描述	Description	数量
1	20007584	摆针曲柄组件	ZIGZAG DRIVE FULL ASSY	1
2	10000996	摆针连杆组件	ZIGZAG ROD ASM.	1
3	10000997	摆针小连杆	ZIGZAG ROD	1
4	10000983	摆针连杆套	SHAFT HOLDER LINK BUSH	2
5	10000981	摆针连杆销	JUNCTION SHAFT A	2
6	10000060	摆针轴挡圈	THRUST COLLAR D15 W11	1
7	10012162	摆针轴挡圈螺钉	SCREW M5 L=5	2
8	10011232	螺钉	SCREW M6 L=6	4
9	10000984	摆针传感器螺钉	SCREW M3X10	1
10	10000342	螺钉	SCREW M4 L=10	6
11	10000980	摆针曲柄螺钉	SCREW M5 L=14	1
12	10009008	摆针大连杆螺钉	SCREW M6 L=18	1
13	10012162	连杆销螺钉	SCREW M5 L=5	4
14	10001001	摆针传感器安装板	SENSOR PLATE	1
15	10000977	摆针传感器	CLOSE SENSOR	1
16	10000059	摆针大连杆	ZIGZAG LEVER REAR	1
17	10000978	摆针电机安装板	MOTOR BASE	1
18	10000979	摆针曲柄	MOTOR LEVER	1
19	10000975	摆针步进电机	NEEDLE SWING MOTOR ASS'Y	1
20	10009008	摆针电机安装板螺钉	SCREW M6 L=10	3
21	10000992	摆针轴组件	ZIGZAG LEVER SHAFT ASM.	1
22	10000994	摆针驱动销螺母	NUT M5	1
23	10000995	摆针轴	ZIGZAG LEVER SHAFT	1
24	10000993	摆针驱动销螺钉	NEEDLE SWING SENSOR ASSY	1
25	10000954	针杆连接柱	NEEDLE BAR CONNECTION	1
26	10000973	连接柱螺钉	NEEDLE_BAR_CONNECTION	1
27	10000989	针杆连接板	NEEDLE BAR ROD	1
28	10000061	摆针滑块	SQUARE BLOCK	1
29	10000062	摆动架组件	NEEDLE BAR FRAME ASSY	1
30	10000063	针杆摆动架	NEEDLE BAR FRAME	1
31	10000982	针杆套	NEEDLE BAR METAL	2
32	10000974	摆动架销	SUPPORT SHAFT	1
33	10000998	摆针压板组件	FRAME SUPPORT PLATE ASM.	1
34	10000990	摆针前套	BUSHING	1
35	10000991	摆针后套	BUSHING REAR	1
36	10000953	针杆	NEEDLE BAR	1
37	10002447	机针 DPX5 #11	NEEDLE DPX5 #11	1
38	10000952	针杆线钩	NEEDLE BAR BOBBIN THREAD GUIDE	1
39	10010588	机针螺钉	SCREW M3 L=5	1
40	10000976	传感器安装定位板	SENSOR PLATE	1

# 7. NEEDLE THREAD TRIMMER COMPONENTS

上切线部件

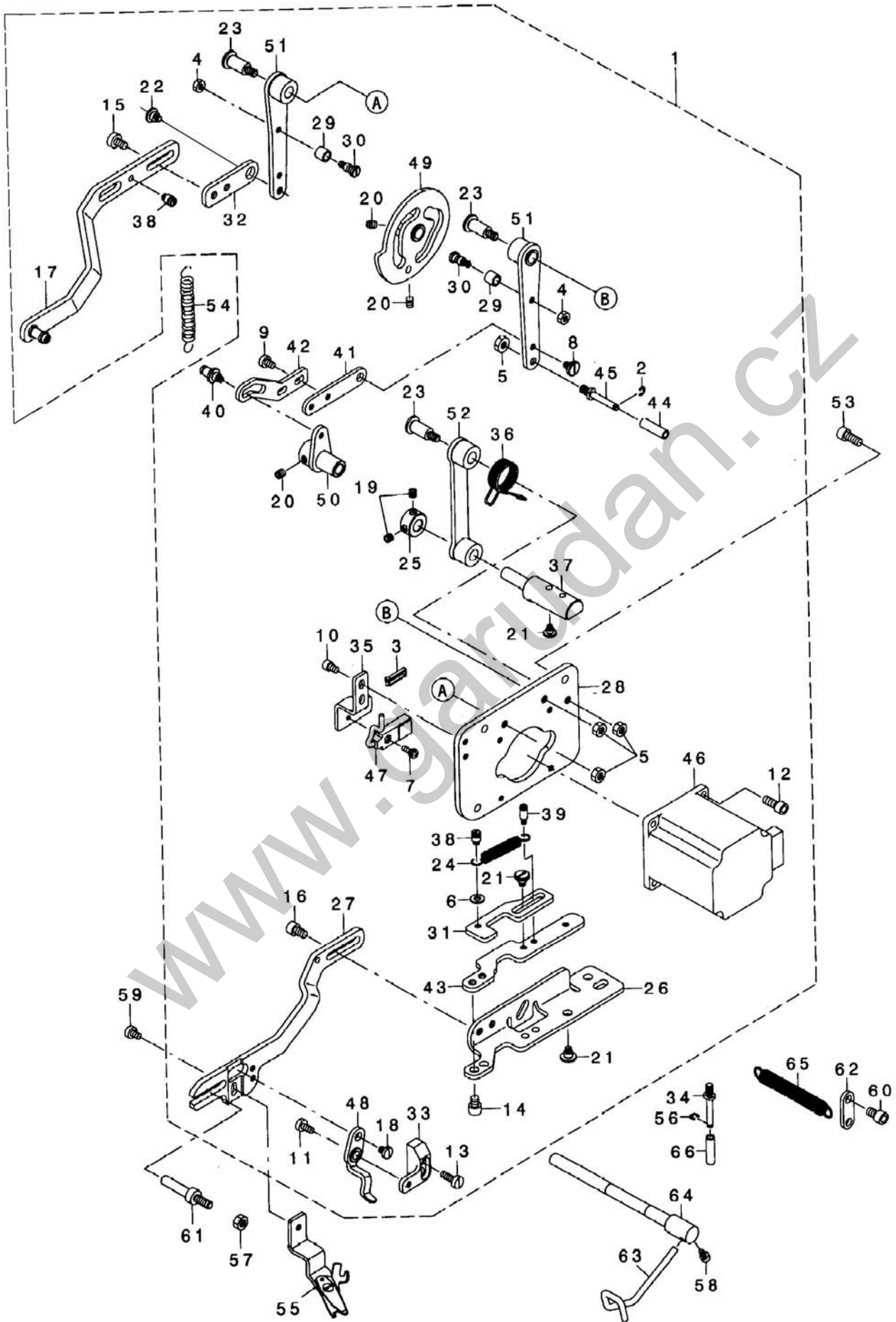



7. 上切线线部件				
NEEDLE THREAD TRIMMER COMPONENTS				
序号 NO.	图号 Part No.	描述	Description	数量
1	10003215	上切线电机组件	ASSY UTT MODULE	1
2	10003248	挡圈	E-RING 3	1
3	10003358	线夹	CABLE BAND	1
4	10002463	螺母	NUT M4	2
5	10000994	螺母	NUT M5	4
6	10002765	垫圈	WASHER 4.3X9X0.8	1
7	10000984	螺钉组件	SCREW ASM.	1
8	10003496	轴位螺钉	SHOULDER SCREW D6 H2.6	1
9	10002762	螺钉	SCREW M4 L=6	2
10	10003399	上切线传感器安装螺钉	SCREW M4 L=6	2
11	10003298	螺钉	SCREW M4 L=8	1
12	10003399	上切线电机螺钉	SCREW M4 L=10	4
13	10009037	螺钉	SCREW M4 L=12	2
14	10003881	上切线X板螺钉	HEXAGON SOCKET HEAD SCREW M5X6	2
15	10002802	螺钉	SCREW M5 L=8	2
16	10003396	紧定螺钉	SCREW M5 L=8	2
17	10002497	上切线松线臂组件	ASSY UTT RELEASE ARM B	1
18	10003262	松线杆固定螺钉	SCREW M4 L=5	1
19	10012162	挡圈紧定螺钉	SCREW M5 L=4	2
20	10012162	螺钉	SCREW M5 L=5	4
21	10003256	轴位螺钉	SHOULDER SCREW D6 H3.2	4
22	10002755	轴位螺钉	SHOULDER SCREW D8 H4	1
23	10003266	轴位螺钉	SHOULDER SCREW D8 H15	3
24	10002767	弹簧	SPRING	1
25	10002760	紧圈	THRUST COLLAR D8 W9	1
26	10002469	上切线支承臂A	UTT ARM A	1
27	10002766	上切线悬臂B	UTT ARM A	1
28	10003263	上切刀部件安装板	UTT BASE PLATE	1
29	10000021	上切线凸轮滚柱	UTT CAM ROLLER	2
30	10002803	上切线凸轮滚柱导向螺钉	UTT CAM ROLLER SHAFT	2
31	10002531	止动平板	UTT RATCH PLATE	1
32	10002533	上切线松线臂 A	UTT RELEASE ARM A	1
33	10003297	松线座	UTT RELEASE LEVER BASE	1
34	10003222	轴	UTT Y-DRIVE SHAFT	1
35	10002751	上切线传感器安装板	UTT SENSOR BASE	1
36	10002758	上切线支架扭簧	UTT_SUPPORT_ARM_SPRING	1
37	10003226	上切线支承轴	UTT SUPPORT SHAFT	1
38	10002764	拉簧短螺钉	UTT SUSPENSION SCREW 4	2
39	10002763	拉簧长螺钉	UTT SUSPENSION SCREW 9	1
40	10003495	轴位连接螺钉	UTT SUSPENSION SHOULDER SCREW	1
41	10003441	上切线连接杆A	UTT THREAD PULLING LINK A	1
42	10003496	上切线连接杆B	UTT THREAD PULLING LINK B	1
43	10002566	上切线X板	UTT X-CAM	1
44	10003223	轴套	UTT Y-DRIVE ROLLER	1
45	10003222	轴	UTT Y-DRIVE SHAFT	1
46	10003215	上切线电机	UT TRIM MOTOR ASS'Y	1

# 7. NEEDLE THREAD TRIMMER COMPONENTS

上切线部件

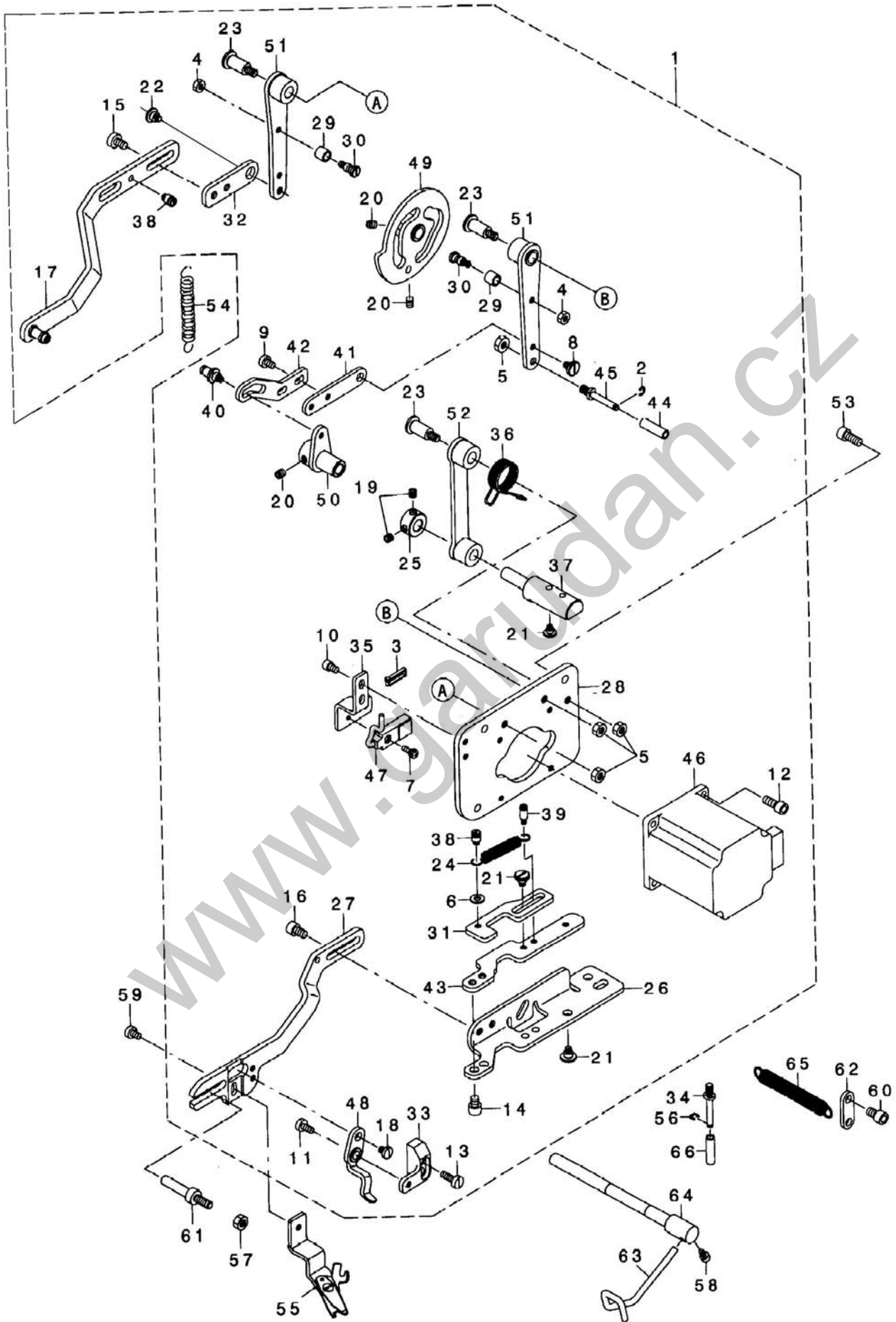

47	10001007	下切线感应器	UT TRIM SENSOR ASS'Y	1
48	10002495	松线拨动杆组件	ASSY UTT RELEASE LEVER	1
49	10002568	上切线凸轮组件	ASSY UTT CAM	1
50	10002448	上切线连接臂组件	ASSY UTT THREAD PULLING ARM	1
51	10002755	上切线凸轮导向板组件	ASSY UTT CAM ARM	1
52	10002498	上切线支承臂组件	ASSY UTT SUPPORT ARM	1
53	10014210	上切线部件安装螺钉	SCREW M5 L=12	3
54	10002761	支承板弹簧	BUTTON SUPPORT LEVER SPRING	1
55	10002450	上切刀组件	ASSY UTT TRIMMER	1
56	10003248	挡圈	E-RING 3	1
57	10000994	螺母	NUT M5	1
58	10003399	螺钉	SCREW M4 L=6	1
59	10002762	切刀组件安装螺钉	SCREW M4 L=6	1
60	10003396	紧定螺钉	SCREW M5 L=8	1
61	10003261	导向轴	UTT GUIDE SHAFT	1
62	10003258	弹簧吊钩板	UTT SUSPENSION PLATE	1
63	10003260	上切线拉线杆	UTT THREAD PULLING LEVER	1
64	10003259	拉线轴	UTT THREAD PULLING SHAFT	1
65	10003257	上切线拉簧	UTT TRIMMER CLOSE SPRING	1
66	10003223	轴套	UTT Y-DRIVE ROLLER	1

# 8. BOBBIN THREAD TRIMMER COMPONENTS

下切线部件

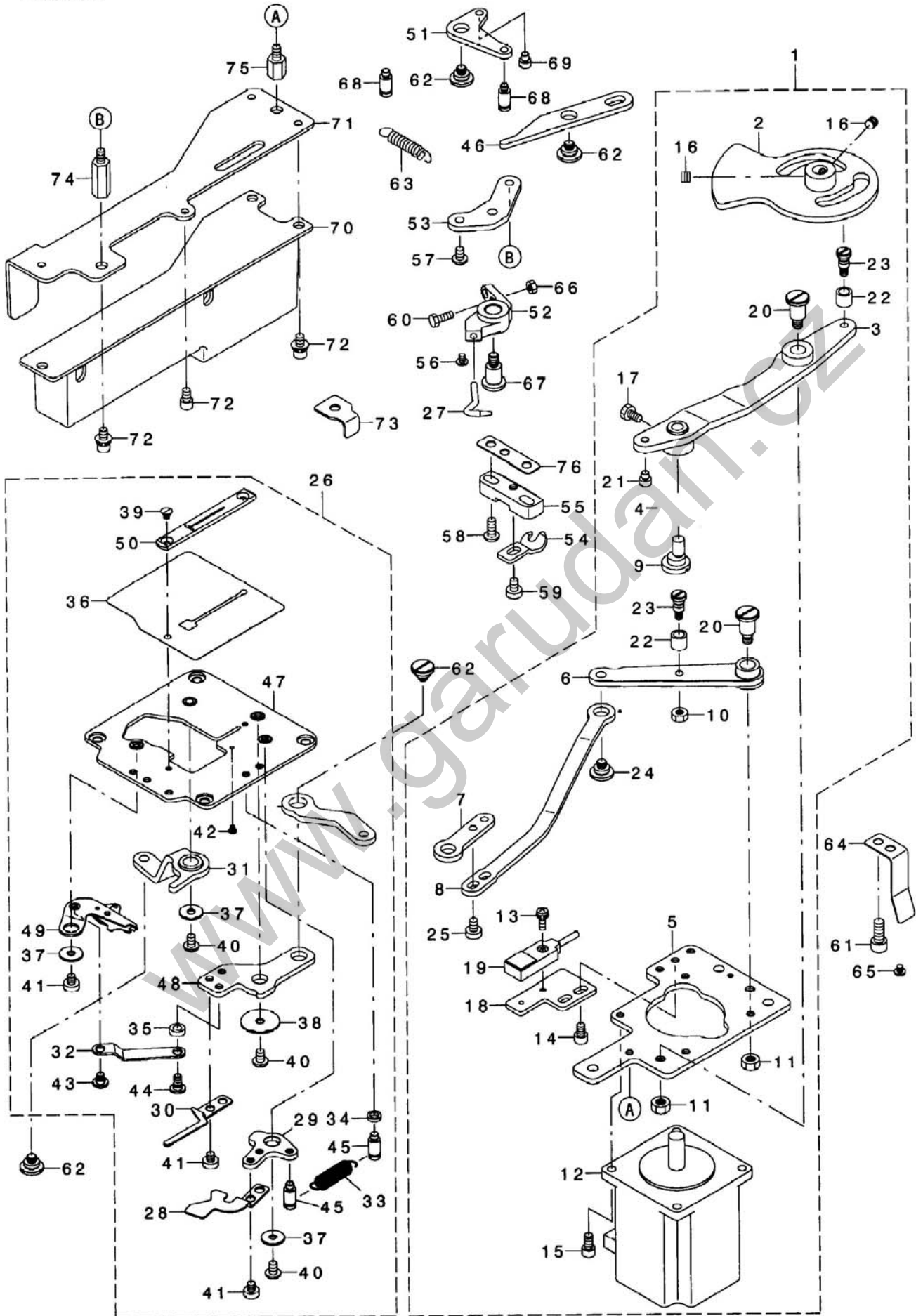

8. 下切线部件				
BOBBIN THREAD TRIMMER COMPONENTS				
序号 NO.	图号 Part No.	描述	Description	数量
1	20007587	下切线电机大组件	BTT_DRIVE_UNIT	1
2	10001143	下切线凸轮组件	ASSY_BTT_DRIVE_CAM	1
3	10001164	下切线主动板组件	ASSY_BTT_DRIVE_LEVER	1
4	10001012	切线传动板	BTT_DRIVE_LINK	1
5	10001009	下切线电机安装板	BTT_DRIVE_UNIT_BASE	1
6	10008447	分刀主动板组件	ASSY_BTT_RELEASE_LEVER	1
7	10001015	分刀传动短杆	BTT_RELEASE_LINK_F	1
8	10001014	分刀传动长杆	BTT_RELEASE_LINK_R	1
9	10001024	切线调节偏心轴	LINK_ROD	1
10	10002076	凸轮滚柱螺钉螺母	NUT_M4	1
11	10001146	分刀主动板组件螺钉螺母	NUT_M5	2
12	10001022	下切线电机	LT_TRIM_MOTOR_ASS'Y	1
13	10000984	下切线传感器螺钉组件	SCREW_M3_X_10	1
14	10010685	传感器安装板螺钉	SCREW_M4_L=6	2
15	10001010	下切线电机螺钉	SCREW_M4_L=8	4
16	10012162	下切线凸轮组件螺钉	SCREW_M5_L=4	2
17	10001013	切线调节偏心轴螺钉	HEXAGONAL_BOLY	1
18	10001021	传感器安装板	SENSOR_FITTING_PLATE_BT	1
19	10001007	下切线传感器	LT_TRIM_SENSOR_ASS'Y	1
20	10001029	螺钉	SHOULDER_SCREW_D8_H10	2
21	10001124	挡线驱动板主动螺钉	STOPPER_PIN	1
22	10000021	凸轮滚柱	UTT_CAM_ROLLER	2
23	10000919	凸轮滚柱螺钉	UTT_CAM_ROLLER_SHAFT	2
24	10001023	分刀传动长杆螺钉	SHOULDER_SCREW_D8_H2.9	1
25	10010554	分刀传动连接螺钉	SCREW_M3_L=6	2
26	10002464	下切线大组件	THROAT_PLATE_BASE_COMPL	1
27	10003487	挡线钩	PICKER	1
28	10000915	上拨线板	BT_CLAMP	1
29	10000910	上拨线板座	BT_CLAMP_LEVER	1
30	10001120	下拨线板	BT_PULLER	1
31	10001126	分刀板组件	ASSY_BT_RELEASE_ARM	1
32	10000022	下切线组件驱动板	BT_TRIMMER_LINK	1
33	10000918	上拨线板拉簧	SPRING	1
34	10000916	上拨线板拉簧紧定螺钉	WASHER	1
35	10000070	下切线组件驱动板长螺钉垫	WASHER	1
36	10001123	针板垫	OIL_SHIELD	1
37	10001017	垫片	PLAIN_WASHER_4.3X12X1	3
38	10001121	下切线板座螺钉垫片	WASHER_4.5X20X1	1
39	10001145	针板螺钉	SCREW_M3_L=4	2
40	10001051	螺钉	SCREW	3
41	10000041	下切刀组件螺钉	SCREW_M4_L=4	9
42	10000917	上拨线定位螺钉	HINGE_SCREW	1
43	10000071	下切线组件驱动板短螺钉	SHOULDER_SCREW_D5_H1.6	1
44	10001144	下切线组件驱动板长螺钉	SHOULDER_SCREW_D5_H1.6	1
45	10001053	上拨线板拉簧动螺钉	SUSPENSION_SCREW	2
46	10001016	挡线驱动板	PICKER_ACTUATING_LEVER	1

# 8. BOBBIN THREAD TRIMMER COMPONENTS

下切线部件

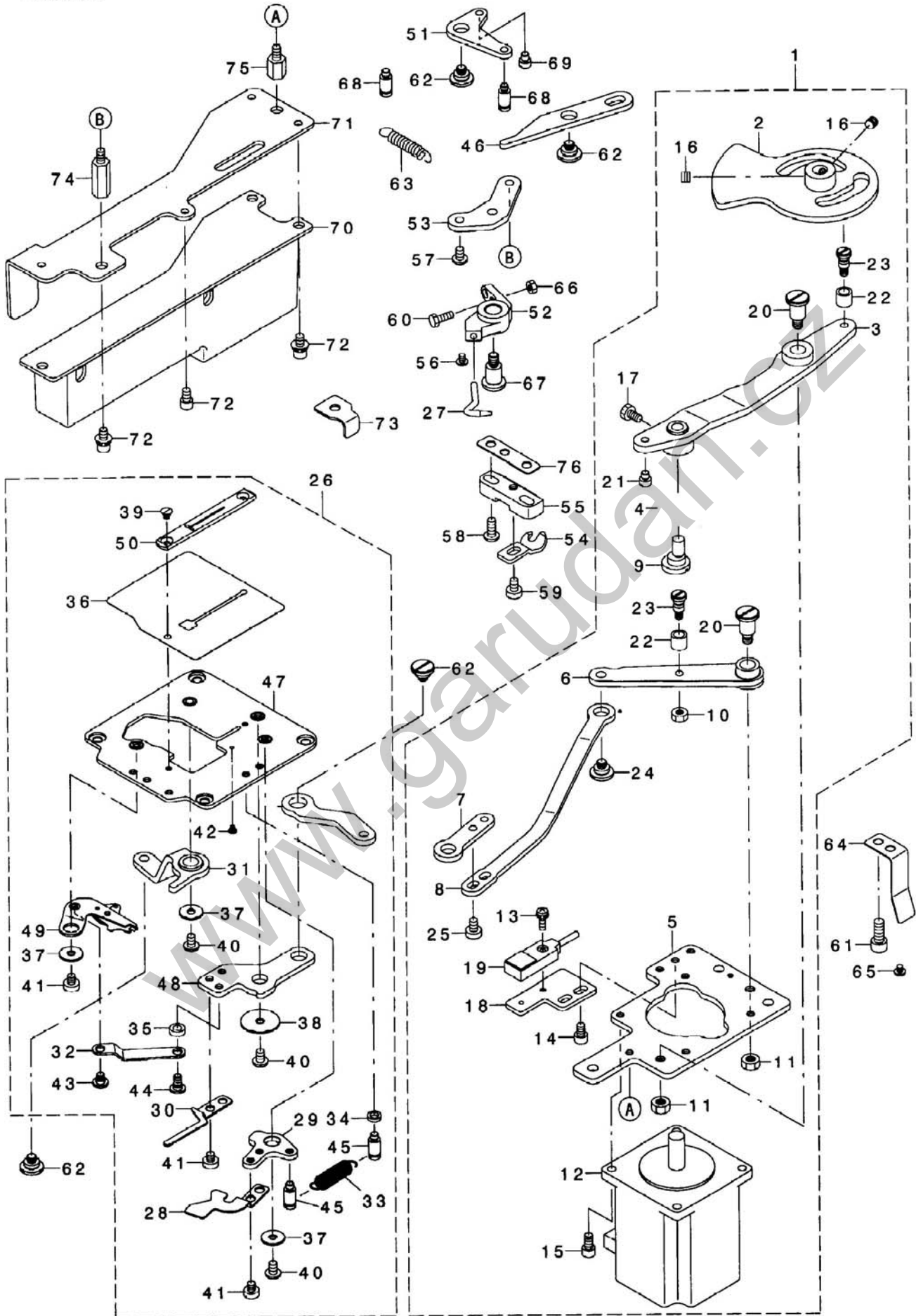

47	10001155	针板座组件	ASSY_THROAT_PLATE_BASE	1
48	10000072	下切线板座	BTT_LEVER	1
49	10001127	下切刀组件	ASSY_BTT_LOWER	1
50	10000074	针板	THROAT_PLATE(K)	1
51	10001052	挡线传动板	PICKER_ACTUATING_L_LINK	1
52	10001028	挡线连接块	PICKER_BASE	1
53	10001026	挡线连接块安装板	PICKER_BASE FITTING PLATE	1
54	10000912	旋梭定位钩	STOPPER A	1
55	10000913	旋梭定位钩座	BOBBIN CASE POSITIONING PLATE	1
56	10000040	挡线钩螺钉	SCREW M3 L=4	1
57	10001027	挡线连接块安装板螺钉	SCREW M4 L=5	1
58	10009104	旋梭定位钩座螺钉	SCREW M4 L=10	2
59	10010554	旋梭定位钩螺钉	SCREW M4 L=6	1
60	10001025	挡线连接块复位螺钉	SCREW M4 L=12	1
61	10001010	下切线电机安装板螺钉	SCREW M5 L=8	3
62	10001023	螺钉	SHOULDER SCREW D8 H2.9	4
63	10000918	上拨线板拉簧	SPRING	1
64	10001020	安全开关挡板	SAFETY SWITCH PRESSING PLATE	1
65	10009529	安全开关挡板螺钉	SCREW	1
66	10002076	挡线连接块复位螺钉螺母	NUT M4	1
67	10001029	挡线连接块螺钉	SHOULDER SCREW D8 H10	1
68	10001053	挡线传动板长螺钉	SUSPENSION_SCREW	2
69	10001018	挡线传动板短螺钉	STOPPER_PIN	1
70	10001137	油盒组件	OIL_TANK_ASM.	1
71	10000073	油盒安装板	OIL_TANK_PLATE	1
72	10001135	油盒组件螺钉	SCREW	6
73	10000911	挡线连接块挡板	PICKER_BASE STOPPER	1
74	10000039	油盒安装长螺钉	STUD	1
75	10001011	油盒安装短螺钉	STUD	1
76	10000914	旋梭定位钩座垫	BTT_SPACER	1

# 9. CLOTH CUTTING KNIFE COMPONENTS

切布刀部件

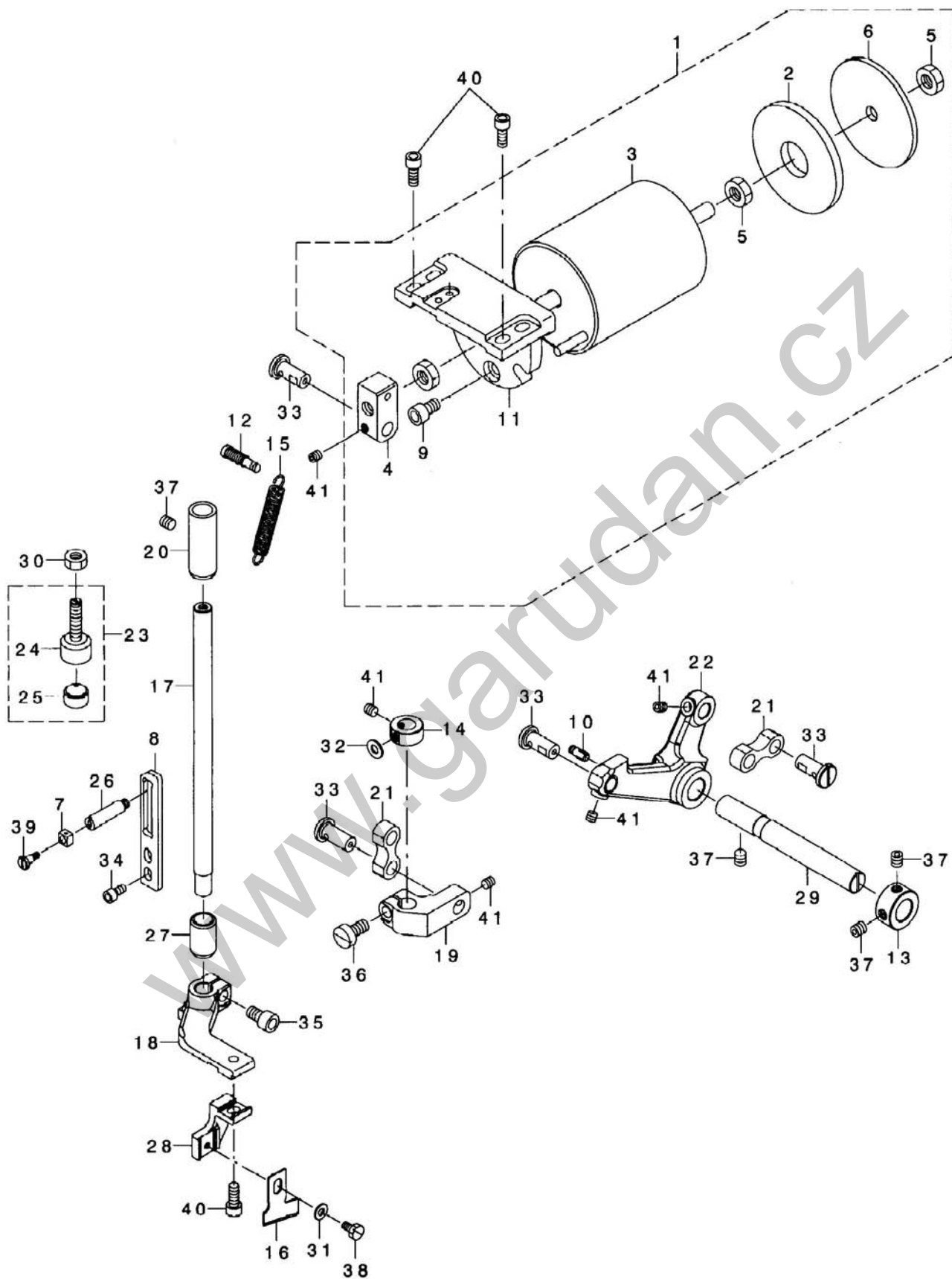



9. 切布刀部件				
CLOTH CUTTING KNIFE COMPONENTS				
序号 NO.	图号 Part No.	描述	Description	数量
1	20007588	切布刀电磁铁大组件	KNIFE SOL ASM.	1
2	10002467	切布刀电磁铁缓冲垫	CUSION	1
3	10008621	切布刀电磁铁组件	SOLENOID	1
4	10001157	电磁铁连接块	KNIFE HOLDER	1
5	10002465	切布刀铁芯轴螺母	NUT M8	3
6	10002466	切布刀电磁铁缓冲限位板	PLATE A	1
7	10001170	切布刀导向滑块	SQUARE BLOCK	1
8	10001182	切布刀导向板	SUPPORT GUIDE	1
9	10003402	切布刀电磁铁螺钉	SCREW M6 L=10	3
10	10001089	双臂曲柄销	SUSPENSION SCREW	1
11	10001190	切布刀电磁铁架	SOLENOID BASE	1
12	10000837	切布刀复位销	SUSPENSION SCREW	1
13	10001158	支轴挡圈	THRUST COLLAR D=12 W=11	1
14	10001184	切布刀导向圈	COLLAR	1
15	10001085	切布刀复位弹簧	SPRING	1
16	10001086	切布刀	KNIFE	1
17	10001169	切布刀竖轴	KNIFE BAR	1
18	10001180	切布刀驱动架	KNIFE BAR BASE	1
19	10001186	切布刀竖轴连接架	KNIFE BAR BRACKET	1
20	10001185	切布刀竖轴上套	KNIFE BAR BUSH	1
21	10001187	双臂曲柄连杆	KNIFE BAR CONNECTING LINK	2
22	10001088	双臂曲柄	KNIFE BAR DRIVING LEVER	1
23	10001084	切布刀缓冲垫组件	KNIFE BAR DRIVING STOPPER ASM.	1
24	10001156	缓冲垫支承螺钉	KNIFE BAR DRIVING STOP SCREW	1
25	10001084	切布刀缓冲垫	KNIFE DRIVING LEVER STOPPER	1
26	10001171	切布刀导向销	KNIFE BAR SUPPORT SHAFT	1
27	10001181	切布刀竖轴下套	KNIFE BAR LOWER BUSHING	1
28	10001160	切布刀架	KNIFE FITTING BASE	1
29	10001191	双臂曲柄支轴	KNIFE LEVER SHAFT	1
30	10001085	缓冲垫螺母	NUT M6	1
31	10002765	切布刀螺钉垫片	WASHER 4.3X9X0.8	1
32	10001172	导向销垫	WASHER 5X10.5X1	1
33	10001173	曲柄销	BELL CRANK SHAFT	4
34	10003399	导向板螺钉	SCREW M4 L=8	2
35	10011824	切布刀驱动架螺钉	SCREW M6 L=12	1
36	10001159	竖轴连接架螺钉	SCREW	1
37	10011232	支轴紧定螺钉	SCREW M6 L=6	4
38	10001189	切布刀螺钉	HEXAGONAL BOLT	1
39	10001183	导向滑块螺钉	SHOULDER SCREW D4 H5	1
40	10005139	电磁铁固定螺钉	SCREW M5 L=12	5
41	10012162	曲柄销紧定螺钉	SCREW M5 L=5	5

# 10. ACCESSORIE PART COMPONENTS

附件

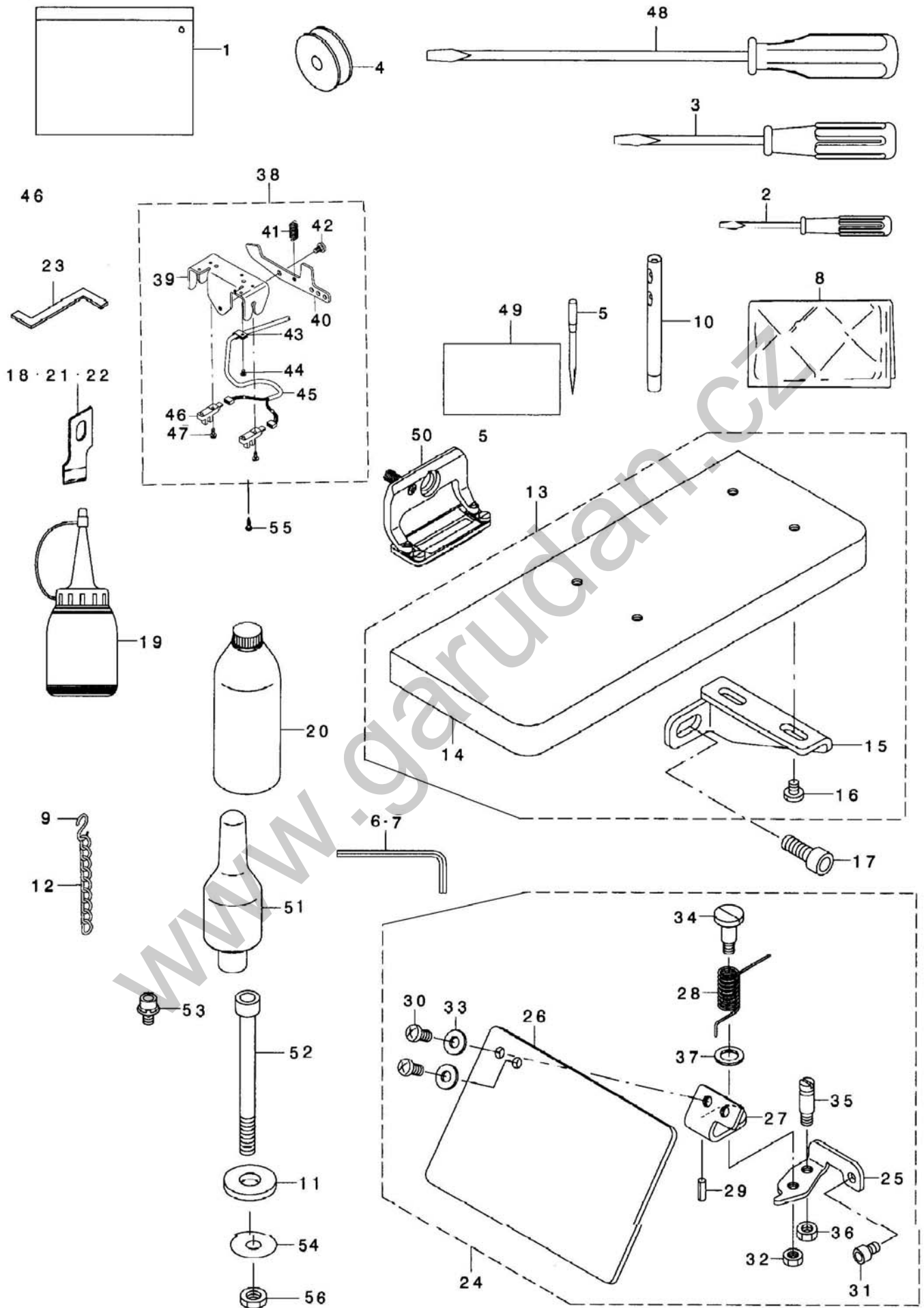

10. 附件				
ACCESSORIES PART COMPONENTS				
序号 NO.	图号 Part No.	描述	Description	数量
1	10001177	机头罩	ACCESSORIE BAG	1
2	10013185	小螺丝刀	SCREW DRIVER, SMALL	1
3	10010995	中螺丝刀	SCREW DRIVER, MIDDLE	1
4	10000880	梭心	BOBBIN	3
5	10002447	机针	NEEDLE DPX5 #11~#14	1
6	10009685	内六角扳手	HEXAGONAL WRENCH KEY	1
7	10009689	内六角扳手	HEXAGONAL WRENCH KEY	1
8	10001056	防震泡膜	VINYL COVER	1
9	10014203	链钩	LINK	1
10	10000167	两眼过线柱	THREAD GUIDE BAR	1
11	10003357	底座锁紧螺钉橡胶垫片	RUBBER CUSHION(B)	4
12	10012456	链条	CONNECTING ROD	1
13	20007589	辅助机台组件	AUXILIARY TABLE COMPL.	1
14	20006740	辅助机台	AUXILIARY TABLE	1
15	10002394	辅助机台安装板	INSTALLING PLATE	2
16	10001095	辅助机台安装板小螺钉	SCREW 11/64-40 L=4.8	4
17	10003402	辅助机台安装板大螺钉	SCREW M6 L=10	2
18	10001192	切布刀	KNIFE 1	1
19	10004455	油瓶	OILER	1
20	10013294	油瓶	DEFRIX OIL NO. 1 (600CC)	1
21	10001093	切布刀	KNIFE 5/8	1
22	10001092	切布刀	KNIFE 3/8	1
23	10001174	高度块	HOOK TIMING GAUGE, K	1
24	20000415	眼睛防护罩组件	ASSY SAFETY PLATE	1
25	10001338	安全板座	SAFETY PLATE FITTING BASE	2
26	10011636	安全板	SAFETY PLATE	1
27	10001339	安全板组件	SAFETY PLATE INSTALLING PLATE	1
28	10011678	安全板弹簧	SAFETY PLATE RETURN SPRING	1
29	10002880	弹性圆柱销	SPRING PIN 2X6	2
30	10011570	安全板螺钉	SCREW 11/64-40 L=7	1
31	10003399	安全板座螺钉	SCREW M4 L=6	1
32	10000100	轴位螺钉螺母	NUT 11/64-40	2
33	10011680	安全板螺钉垫片	WASHER 4.5X10X0.8	1
34	10011677	安全板轴位螺钉	HINGE SCREW D=6 H=10.2	1
35	10011633	弹簧复位销	TENSION SPRING RACK B	1
36	10011682	复位销螺母	NUT 3/16-28	1
37	10001289	轴位螺钉垫片	WASHER 7.4X10X0.8	1
38	20007590	踏脚开关组件	ASSY 4 POSITION PEDAL	1
39	10004701	踏脚开关架	PEDAL FRAME	1
40	10011634	踏脚开关	PEDAL FRAME	1
41	10011631	踏脚开关弹簧	SPRING	1
42	10011647	踏脚开关螺钉	SCREW	1
43	10022510	线夹	CABLE CLAMP	1
44	10011754	线夹螺钉	SCREW	1
45	10001283	踏脚开关传感器电线	WIRE	1
46	10006278	传感器	PHOTO SENOR	2

# 10. ACCESSORIE PART COMPONENTS

附件

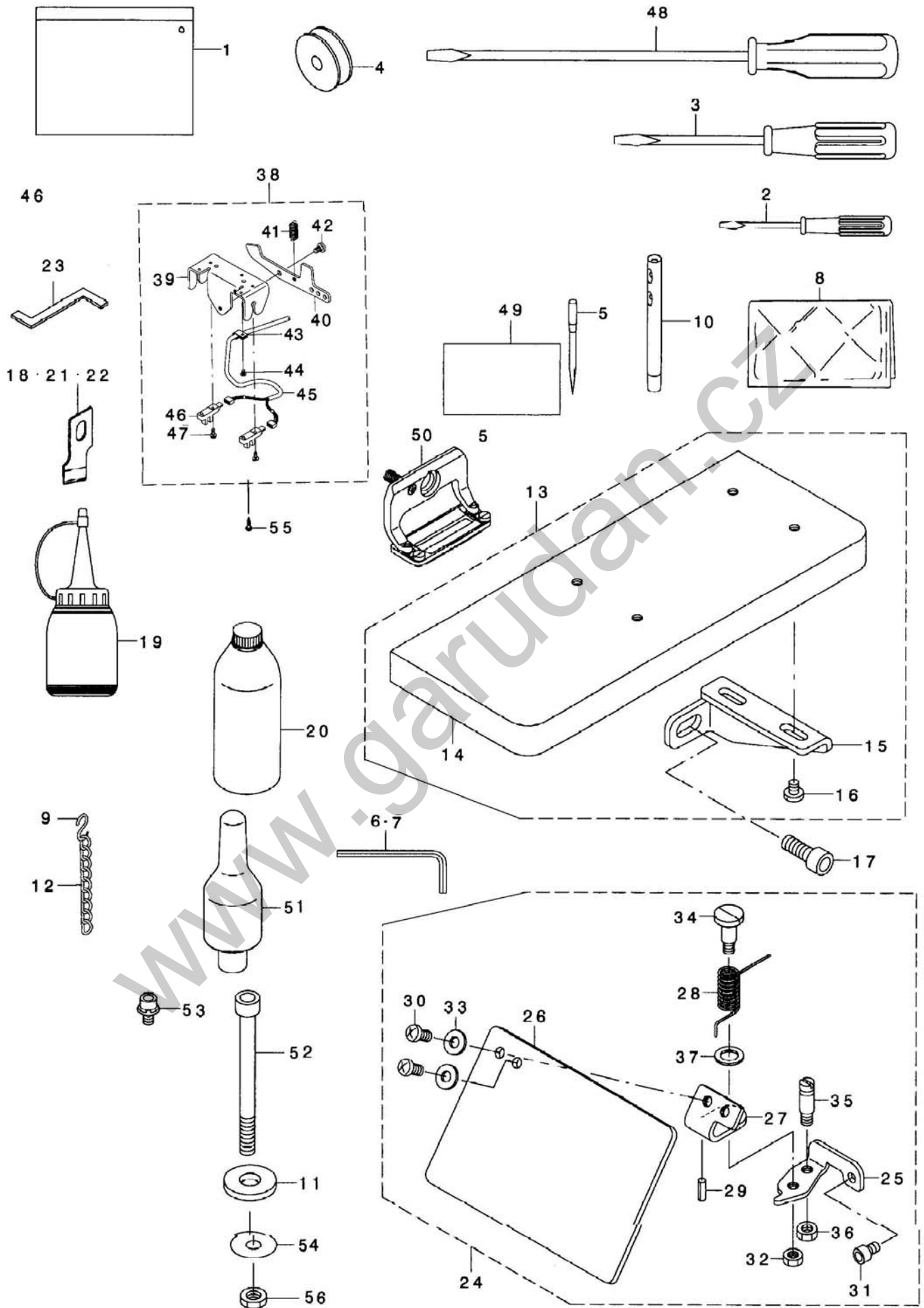

47	10011199	传感器固定螺钉组件	SCREW	3
48	10010994	大螺丝刀	SCREW DRIVER, LARGE	1
49	10001241	塑料薄膜	EC PRODUCTION DECLARATION	1
50	10001116	拾压脚柄组件	PREDDER FOOT 2 ASM.	1
51	10011749	机头支承杆	HEAD SUPPORT BAR	4
52	10003832	底板锁紧螺钉	HEXAGON BOLT	4
53	10003875	接地线螺钉组件	BOLT	1
54	10003395	底座锁紧螺钉垫片	WASHER 6. 1X18. 5X2	4
55	10008323	踏脚开关安装木螺钉	WOOD SCREW D=4. 8 L=20	2
56	10003078	底座锁紧螺母	NUT M6	8

www.garudan.cz

# 11. THREAD STAND COMPONENTS

过线架部件

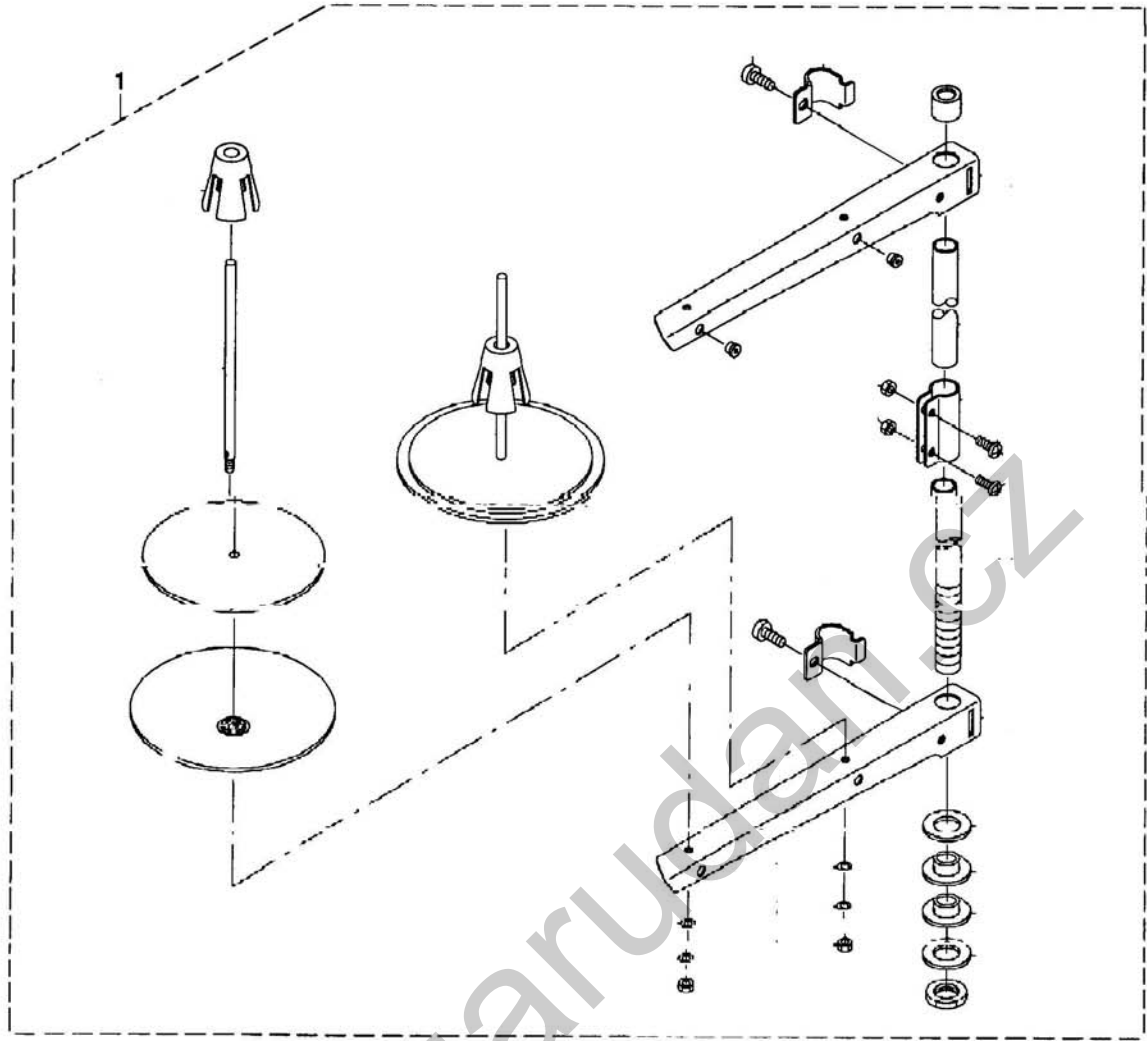

序号	图号	描述	DESCRIPTION	数量
1	20001171	过线架组件	THREAD STAND ASM.	1

## 12. CONTROL BOX COMPONENTS

电控部件

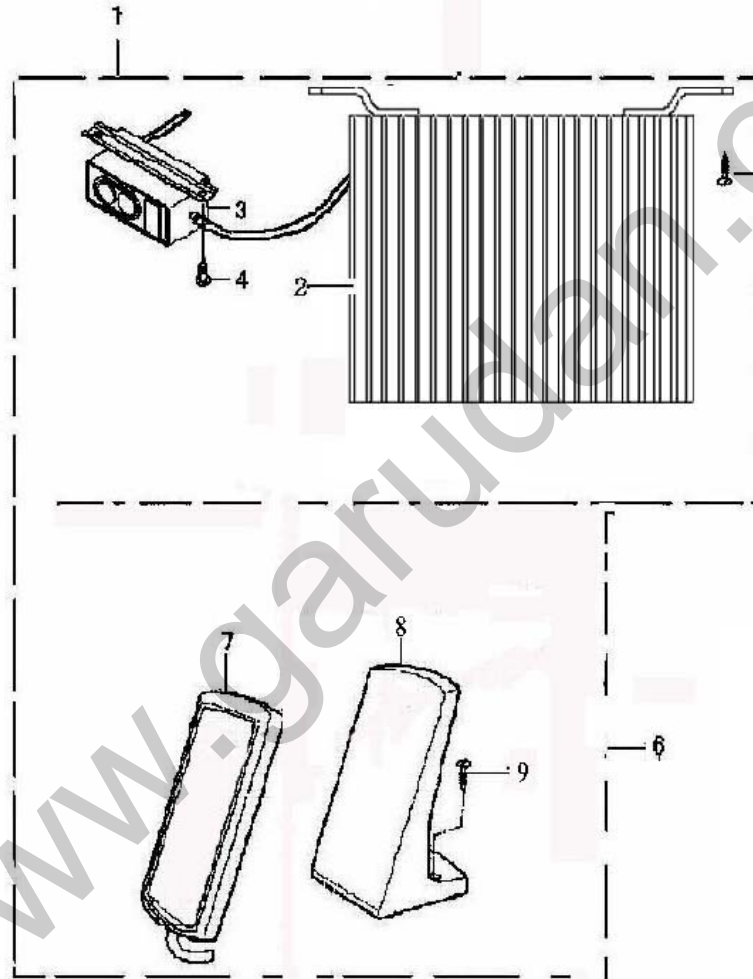

12. 电控部件				
CONTROL BOX COMPONENTS				
序号 NO.	图号 Part No.	描述	Description	数量
1	20007591	电控系统	CONTROL BOX	1
2	10025125	控制箱体	CONTROL BOX ASSEMBLY	1
3	10001298	电源开关	POWER SWITCH	1
4	10008323	电源开关螺钉	SCREW	2
5	10001118	螺钉	SCREW	3
6	10021351	操作盒组件	OPERATION BOX	1
7	10025126	操作盒	OPERATION BOX	1
8	10022012	操作板座	OPERATION BOX PLATE	1
9	10001118	操作盒安装螺钉	SCREW	2

www.garudan.cz